

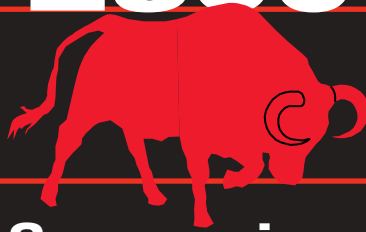

**2300**



**Truck Suspension Series**

# **Parts & Installation**



**Advancing the Practical Application of Suspension Technology**

Springfield, MO ■ (800) 654-8824 ■ (417) 862-5012  
Fax (417) 862-2317 ■ [www.hutchensindustries.com](http://www.hutchensindustries.com)

# 2300 Truck Suspension Series

## Features

- ▶ The 2300 Series suspensions are designed for truck and truck tag axle applications. A half-tandem unit is also available for converting single truck suspensions to tandem axle models.
- ▶ The 2300 Series models feature side-mount, bolt-on type spring hangers. All hangers, equalizers and axle seats are of the highest quality cast steel and are engineered for heavy-duty service.
- ▶ The unit is completely rubber bushed - which eliminates metal to metal contact and the need for lubrication. Torque arm bushings are a two-piece tapered design - permitting ease of installation and replacement.
- ▶ Special heavy-duty springs engineered to provide the ride characteristics and load - carrying capabilities required for most truck applications.
- ▶ Three choices of rocker bushings - bonded rubber, phenolic or bronze - provide the versatility required for truck applications.
- ▶ Axle seats are available for most popular axles including 5" round. In addition, an adjustable axle seat is available to fit 4" to 5 1/2" square axles.
- ▶ The 2300 Series features a variable equalizer that makes it possible to approximate either 50/50 or 60/40 weight distribution.
- ▶ Torque arm screw threads are coated with "NEVER-SEEZ<sup>®</sup>" to prevent corrosion and make adjustments easier. Torque arm eye ends are of an extra strong, wrap-around design.
- ▶ This heavy-duty, lubrication-free suspension is the best answer when you need a rugged and dependable truck suspension.

## 2300 Series Configurations

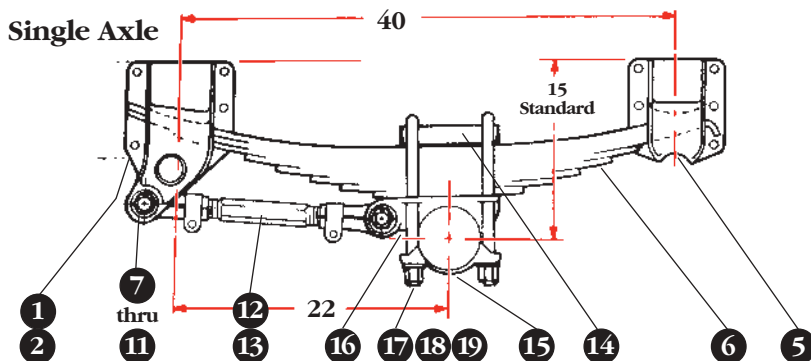

### Tandem Axle

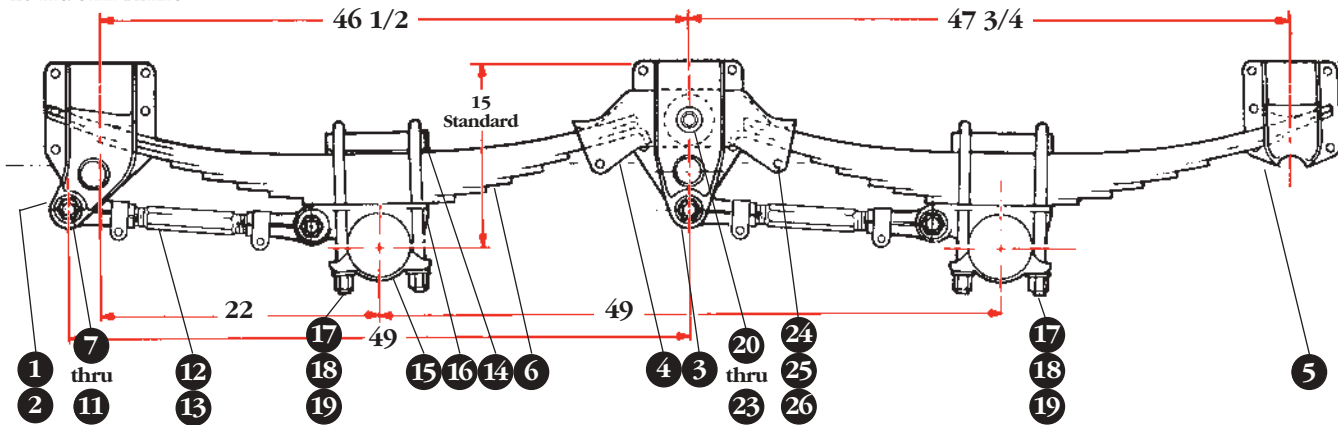

### Lead Axle

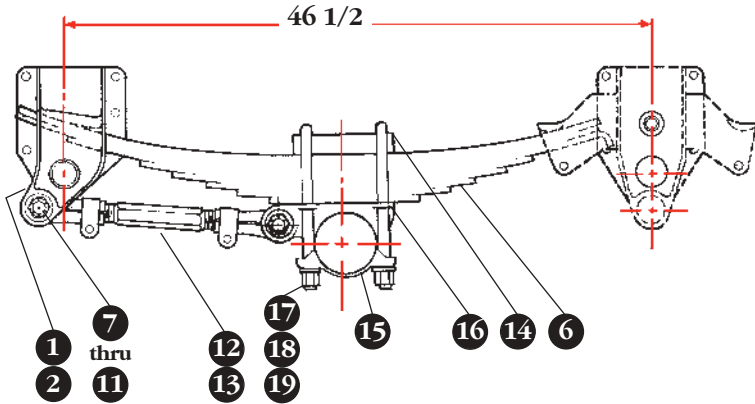

### Tag Axle

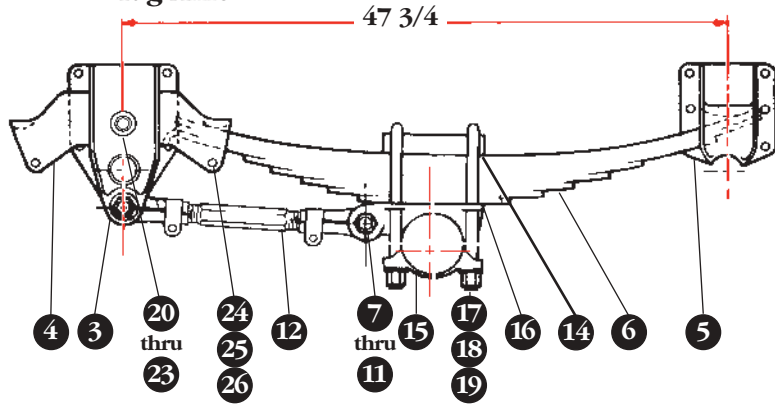

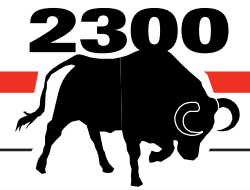

## Bill of Materials

Item	Part Number	Quantity			Tag Axle	Description
		Single Axle	Tandem Axle	Lead Axle		
1	2201-03	1	1	1	—	Spring Hanger - Front, Cast LH
2	2201-04	1	1	1	—	Spring Hanger - Front, Cast RH
3	18739-01	—	2	—	2	Rocker Hanger - Cast
4	2224-01 or 2224-03 or 18747-01	— — —	2 2 2	— — —	2 2 2	Rocker Assembly - Cast, Phenolic Bushing Rocker Assembly - Cast, Bronze Bushing Rocker Assembly - Cast, Rubber Bushing
5	2203-01	—	2	—	2	Spring Hanger - Rear, Cast
6	2252-00	2	4	2	2	Spring Assembly - 8-leaf
7	2219-01	4	8	4	4	Torque Arm Bolt
8	30-00	4	8	4	4	Hex Nut - Slotted, 1" - 14 UNS - 2B
9	28-00	4	8	4	4	Cotter Pin - 1/8" x 2 LG
10	227-00	8	16	8	8	Washer - 1 1/16 ID x 2 1/2 OD
11	222-00	8	16	8	8	Rubber Bushing - Torque Arm, Half
12	16399-01	1	3	1	2	Torque Arm Assy. - Adj., Solid Screw, 19 1/4 LG
13	784-02	1	1	1	—	Non-Adj. Torque Arm - 19 1/4"
14	17162-01	2	4	2	2	Top Plate Assy. - Half Round
15	See Chart A	2	4	2	2	Bottom Plate
16	See Chart B	2	4	2	2	Spring Seat
17	See Chart B	4	8	4	4	U-Bolt
18	35-00	8	16	8	8	Washer - PL, 15/16 ID x 1 3/4 OD
19	34-04	8	16	8	8	Hex Nut - 7/8" - 14 UNF - 2B
20	18628-01	—	2	—	2	Hex Cap Screw - 1 1/8" - 7 UNRC x 6 5/8 LG, GR5
21	11154-00	—	2	—	2	Hex Lock Nut - 1 1/8" - 7 UNC - 2B, GRB
22	837-00	—	4	—	4	Washer - 1/8" x 1 1/4 ID x 2 1/4 OD
* 23	18738-01	—	2	—	2	Rocker Bushing Hub
24	759-00	—	4	—	4	Hex Bolt - 5/8" - 18 UNF x 4 1/2, GR2
25	756-00	—	4	—	4	Tube - 3/4 OD x 18 GA x 3 1/4 LG
26	37-03	—	4	—	4	Hex Lock Nut - 5/8" - 18 UNE, GRB

\* Note: Not required if using the 18747-01 Rocker Assembly.

### Adjustable Square Axle

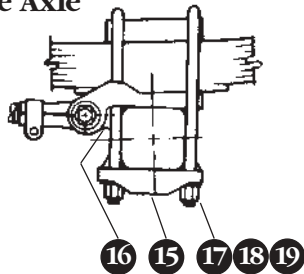

### Chart A - Bottom Plate (Item #15)

Axle Size	Bottom Plate	Adjustment Lug (2 req.)	Bearing Strap
5" Round	710-00	NR	NR
5 1/2" Round	11392-00	NR	NR
Adj. Square	2212-00	2216-00	2209-00

### Chart B - Seat & U-Bolt (Items #16 & 17)

#### 5" Round

Seat Height	Mtg. Height	Spring Seat	U-Bolt (Length)
3/4"	15"	206-01	7040-11 (12 1/4")
2 1/4"	16 1/2"	206-02	7040-14 (13 3/4")
3 1/8"	17 3/8"	206-03	7040-16 (14 3/4")
4 3/4"	19"	206-04	7040-19 (16 1/4")

#### 5 1/2" Round

Seat Height	Mtg. Height	Spring Seat	U-Bolt (Length)
3/4"	15 1/4"	2226-00	7040-12 (12 3/4")

### Adjustable Square Axle

Seat Height	Mtg. Height	Spring Seat	U-Bolt (Length)
1 1/8"	15 1/2"	2221-00	7040-15 (14 1/4")
2 1/4"	16 1/2"	2222-00	7040-17 (15 1/4")
3 1/8"	17 3/8"	2223-00	7040-18 (15 3/4")

# Installation

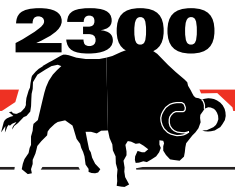

## Step One:

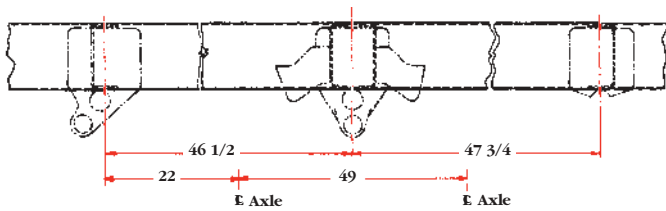

- A) Mark existing drive axle location on inside of the frame for later reference (both sides).
- B) Clean off frame.
- C) Frame should be designed for or reinforced for tandem operation. It may be necessary to completely double-frame the unit. Check manufacturer's recommendations.
- D) Determine desired location of axles. Using the reference mark on frame for alignment, mark location of hangers and install cross-members as shown.

## Step Two:

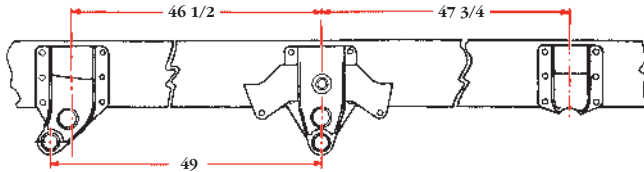

- A) Proper hanger height is obtained by adding one-half the diameter of the tire to the dimension given in the parts list (centerline of axle to top of hanger). Dimensions are no-load.
- B) If frame cannot be maintained parallel with ground, then hangers must be installed parallel with ground for equal weight distribution.
- C) Rear hanger may be set in and down to a minimum of 43 3/4" from equalizer bracket for additional weight on rear axle.
- D) Assemble equalizer and bracket before mounting to frame. For equal weight distribution between axles, install equalizer with 50/50 to front. For additional weight on front axle, install equalizer with 60/40 to front. (Example: front drive axle with tag.) Tighten 1 1/8" rocker bolt to 590 lb-ft (oiled), 790 lb-ft (dry) torque.
- E) Clamp hangers in place and line drill for 5/8" bolt (not furnished). Install pipe braces. Hangers may be bolted or welded or both. If desirable, provide equalizer bolt access in frame.

## Step Three:

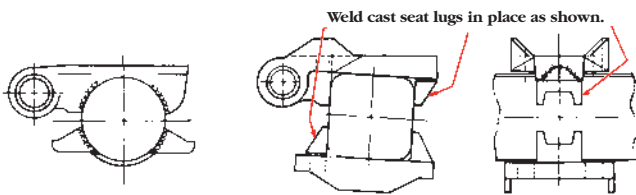

- A) Determine spring centers by adding 6" (3" each side) to frame width. (Example: 30" frame plus 6" equals 36" spring centers.)  
**Note:** Measure frame after reinforcing.
- B) Put axle seats in place, and check with level to be sure that both are even.
- C) Clamp seat and bottom plate in place, check with level and weld. (Check axle manufacturer for welding recommendations.)  
**Note:** On tapered drive axles it may be necessary to shim one side of seat(s) to maintain seat level. To increase vertical pitch in drive axle, install wedges (not furnished) between seat and spring. (Maintain existing drive axle pitch.)

## Step Four:

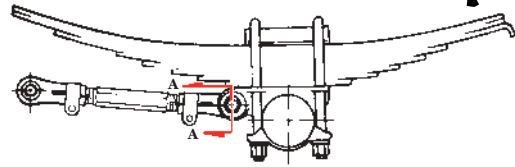

Section AA  
Showing Torque Arm Bolt and Bushing Assembly

- A) Position springs on axle seats so the hook end will be in equalizer. Put top plate and U-bolts in place, and align springs by measuring across ends and diagonally. Tighten nuts to 350 lb-ft (oiled), 470 lb-ft (dry) torque.
- B) Install torque arms in seat and roll axle assembly in place. Tighten torque arm nuts until cotter key can be inserted in castellated nut. Install non-adjustable torque arm in front on curb side.
- C) Install 5/8" keeper bolts in equalizer and tighten to 35 lb-ft (oiled), 50 lb-ft (dry) torque.
- D) Align axles using reference mark on frame. Tighten 5/8" torque arm clamp bolts to 130 lb-ft (oiled), 170 lb-ft (dry) torque.

## Step Five:

Check U-bolts for proper torque. Check again after a short break-in, and periodically thereafter on a regular basis. Check for proper clearance with full axle articulation.

## Tag Axle:

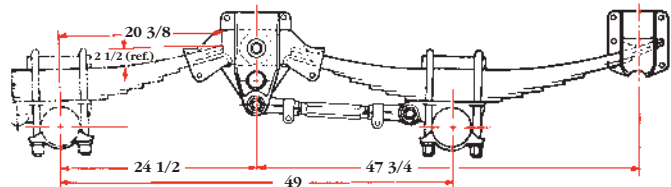

- A) Check existing suspension to see if it can be converted to tandem operation.
  - 1) Frame should be designed for or reinforced for tandem operation.
  - 2) Existing spring must not be more than 3" wide.
- B) It may be necessary to completely double-frame the unit for tandem operation.
- C) Rebuild rear of existing spring to match hook end of the Hutch spring as closely as possible. It may be necessary to shorten all leaves of existing spring; shorten 4th leaf to 6" from end.
- D) Tag axle spring center must match existing spring centers. It may be necessary to install spacers behind hangers. Follow dimensions shown and install hangers (see Step Two). Follow preceding Steps Three, Four and Five. Align tag axle with existing axle.

## 2250 Axle Control Kit:

For additional stability and control, the 2250 Axle Control Kit may be specified. Install as shown with upper and lower torque arms parallel.

