

This confidential drawing is the property of Hutchens Industries. Hutchens Industries makes no warranties regarding the information on this document. Nothing herein may be transmitted or disclosed in whole or in part to other parties. The recipient of this drawing agrees not use the information for manufacturing, nor will they modify, distribute, reverse engineer, or create derivative works based on the information contained on this print without the prior written permission of Hutchens Industries. The recipient agrees not to make copies of the document or reproduce in any manner the information in the document and to return it to Hutchens Industries upon request. Any use of this document is acceptance of the terms stated above.

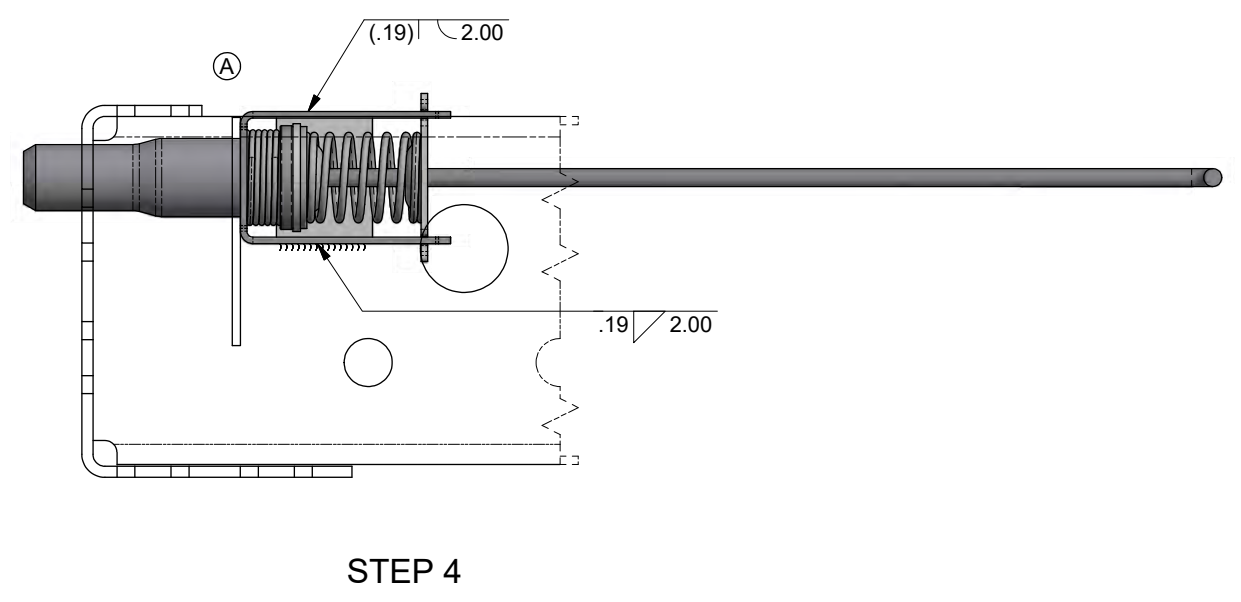
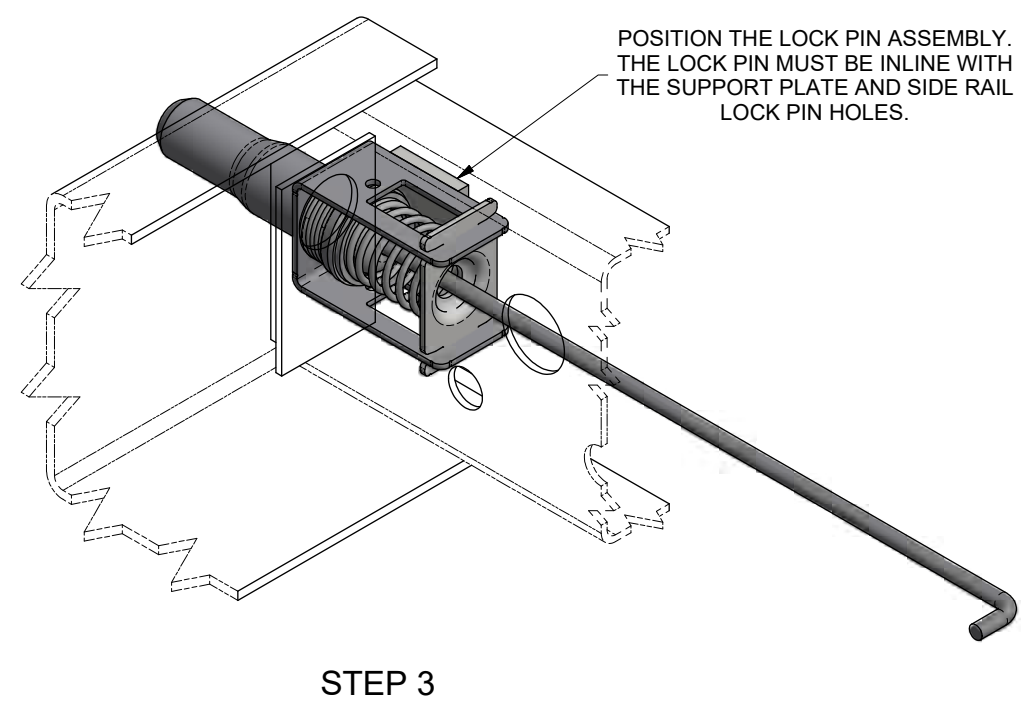
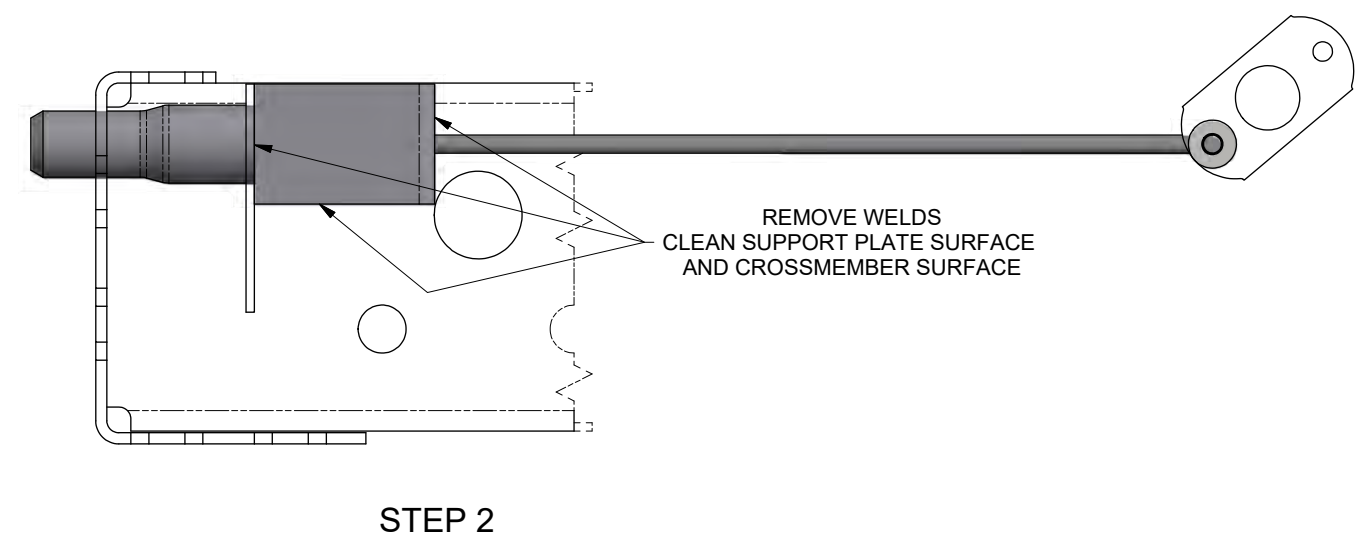
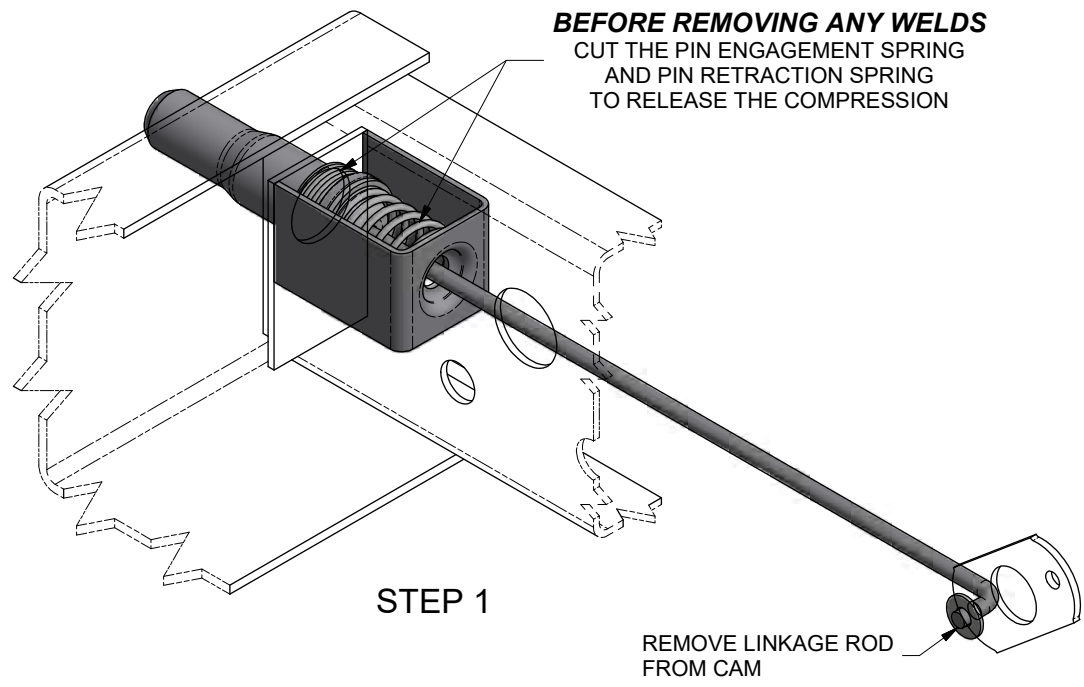

3. MAKE SURE LOCK PINS EXTEND AND FULLY RETRACT BEFORE PLACING SLIDER IN SERVICE.
2. SLIDER MODEL: NEWAY NSB SLIDES.
1. INSTALLATION PROCEDURE FOR KIT 29571-03.

2018224	A	PICTORIALLY UPDATED PER PIN CAGE CHANGE.				12/18	ML	JAJ	RSB	
ER NO.	SYM	REVISIONS				DATE	BY	CHK	APPD	
DRAWN: ML	DATE: 3/22/2018			HUTCHENS INDUSTRIES, INC. SPRINGFIELD, MISSOURI						
CHECKED: JAJ	DATE: 10/3/2018			TITLE: INSTALLATION PROCEDURE FOR 29571-03 KIT						
APPROVED: RSB	DATE: 10/3/2018			PROJECT OR FILE REFERENCE NO. PROJ#: 20180400 EPR#: 20180400-01						
MFG APPL: N/A	DATE: XX/XX/XX			SCALE: D SIZE - 1/2 B SIZE - 1/4						
ER: 2018044	DATE: 10/4/2018	SHEET 1 OF 2		SIZE: D	DRAWING NO.: 29561		REV. A	1 OF 2		
TOLERANCES (UNLESS OTHERWISE SPECIFIED) DECIMAL .X ± .1 DECIMAL .XX ± .06 DECIMAL .XXX ± .030 ANGULAR ± 1° HOLES: .50 DIA AND LESS: ± .007 .51 DIA AND GREATER: ± .01 REMOVE ALL SHARP BURRS & SHARP CORNERS THAT MIGHT AFFECT ASSEMBLY, APPEARANCE, OR OPERATION OF OUR PRODUCTS.										

This confidential drawing is the property of Hutchens Industries, Hutchens Industries makes no warranties regarding the information on this document. Nothing herein may be transmitted or disclosed in whole or in part to other parties. The recipient of this drawing agrees not to use the information for manufacturing, nor will they modify, distribute, reverse engineer, or create derivative works based on the information contained on this print without the prior written permission of Hutchens Industries. The recipient agrees not to make copies of the document or reproduce in any manner the information in the document and to return it to Hutchens Industries upon request. Any use of this document is acceptance of the terms stated above.

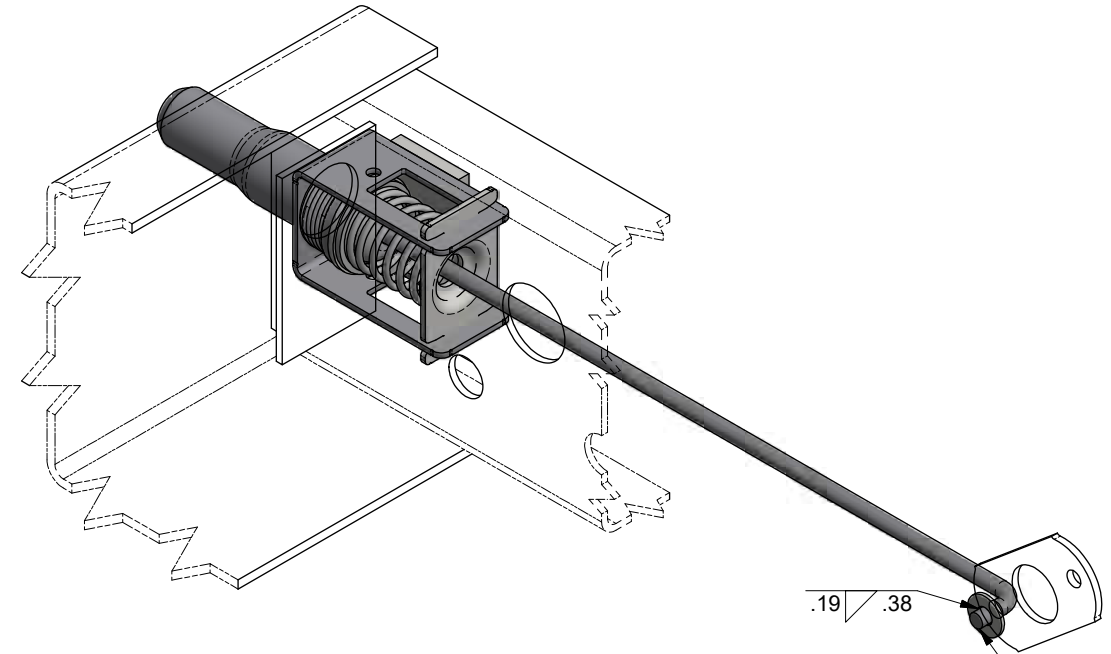

STEP 5

HOOK THE END OF THE LINKAGE ROD THROUGH THE CAM.
 PLACE THE WASHER ON THE LINKAGE ROD
 ON THE OPPOSITE SIDE OF THE CAM.
 WELD THE WASHER ON THE LINKAGE ROD.

- 3. MAKE SURE LOCK PINS EXTEND AND FULLY RETRACT BEFORE PLACING SLIDER IN SERVICE.
- 2. SLIDER MODEL: NEWAY NSB SLIDES.
- 1. INSTALLATION PROCEDURE FOR KIT 29571-03.

2018224		A	PICTORIALLY UPDATED PER PIN CAGE CHANGE.				12/18	ML	JAJ	RSB
ER NO.	SYM	REVISIONS				DATE	BY	CHK	APPD	29561
DRAWN: ML		DATE:	3/22/2018							
CHECKED: JAJ		DATE:	10/3/2018							
APPROVED: RSB		DATE:	10/3/2018							
MFG APPL: N/A		DATE:	XX/XX/XX							
ER: 2018044		DATE:	10/4/2018							
PROJECT OR FILE REFERENCE NO.		PROJ#: 20180400								
		EPR#: 20180400-01								
TOLERANCES (UNLESS OTHERWISE SPECIFIED)		DECIMAL .X ± .1								
		DECIMAL .XX ± .06								
		DECIMAL .XXX ± .030								
		ANGULAR ± 1°								
HOLES:		.50 DIA AND LESS: ± .007								
		.51 DIA AND GREATER: ± .01								
		REMOVE ALL SHARP BURRS & SHARP CORNERS THAT MIGHT AFFECT ASSEMBLY, APPEARANCE, OR OPERATION OF OUR PRODUCTS.								
SCALE:		D SIZE - 1/2		SHEET 2 OF 2		SIZE: D		DRAWING NO.: 29561		REV. A
		B SIZE - 1/4								2 OF 2



INSTALLATION PROCEDURE FOR 29571-03 KIT

DRAWING NO. 29561 REV. A 2 OF 2