

STEP 1

POSITION THE SPRING CAGE. THE LOCK PIN HOLE MUST BE INLINE WITH THE SUPPORT PLATE HOLE.

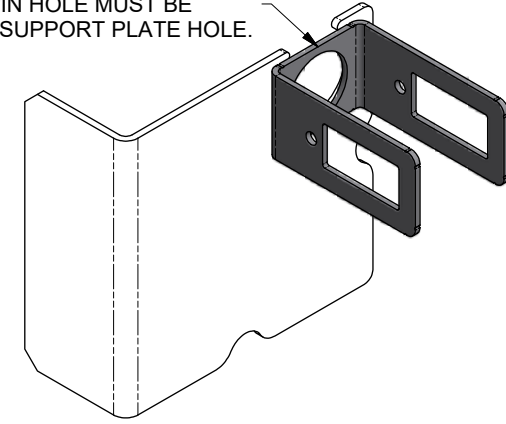

ALLOW THE WELDS TO COOL BEFORE STEP 3.
STEP 2

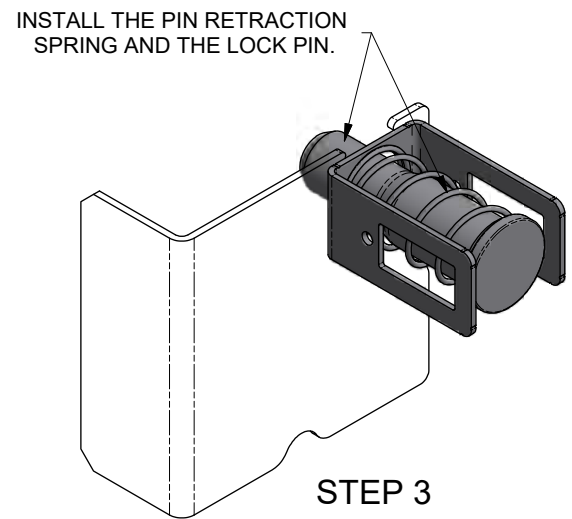
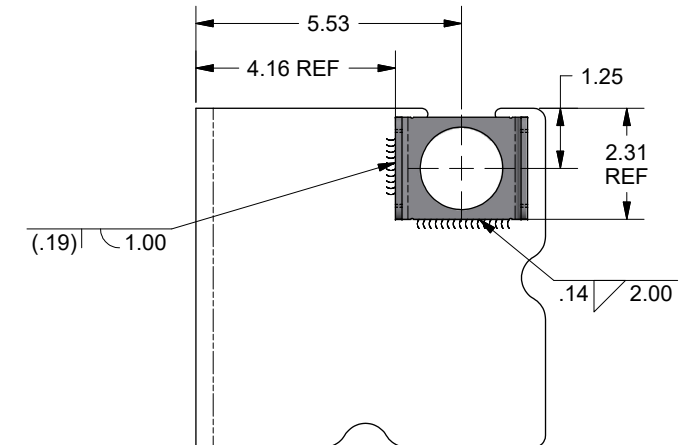

STEP 3

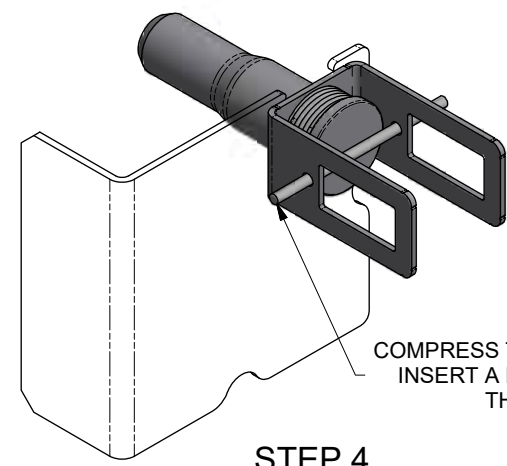

STEP 4

3. MAKE SURE LOCK PINS EXTEND AND FULLY RETRACT BEFORE PLACING SLIDER IN SERVICE.
2. SLIDER MODEL: MERITOR RHP 11.
1. INSTALLATION INSTRUCTION FOR KIT 29571-01.

NEXT ASSY: NEXT		ER NO.	SYM	DATE	BY	CHK	APPD
TOLERANCES (UNLESS OTHERWISE SPECIFIED)		DRAWN:	ML	3/22/2018			
DECIMAL .X ± .1		CHECKED:	JAJ	10/4/2018			
DECIMAL .XX ± .06		APPROVED:	RSB	10/4/2018			
DECIMAL .XXX ± .030		MFG APPL:	N/A	XXXXXX			
ANGULAR ± 1°		ER:	2018044	10/5/2018			
HOLES:		PROJECT OR FILE REFERENCE NO.	PROJ#: 20180400				
.50 DIA AND LESS: ± .007		EPR#:	20180400-01				
.51 DIA AND GREATER: ± .01		SCALE:	D SIZE - 1/2		SHEET 1 OF 2		
REMOVE ALL SHARP BURRS & SHARP CORNERS THAT MIGHT AFFECT ASSEMBLY, APPEARANCE, OR OPERATION OF OUR PRODUCTS.		B SIZE - 1/4		DRAWING NO.:		29563	



HUTCHENS INDUSTRIES, INC.
SPRINGFIELD, MISSOURI

INSTALLATION PROCEDURE FOR 29571-01 KIT

This confidential drawing is the property of Hutchens Industries, Hutchens Industries makes no warranties regarding the information on this document. Nothing herein may be transmitted or disclosed in whole or in part to other parties. The recipient of this drawing agrees not to use the information for manufacturing, nor will they modify, distribute, reverse engineer, or create derivative works based on the information contained on this print without the prior written permission of Hutchens Industries. The recipient agrees not to make copies of the document or reproduce in any manner the information in the document and to return it to Hutchens Industries upon request. Any use of this document is acceptance of the terms stated above.

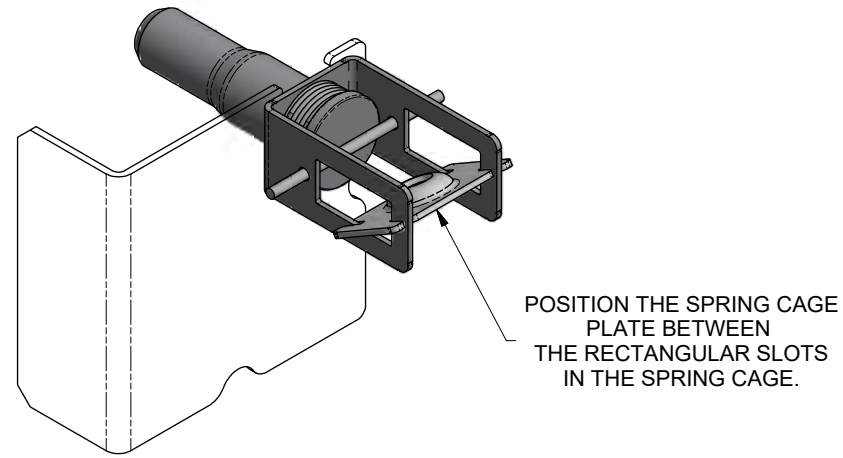

POSITION THE SPRING CAGE PLATE BETWEEN THE RECTANGULAR SLOTS IN THE SPRING CAGE.

STEP 5

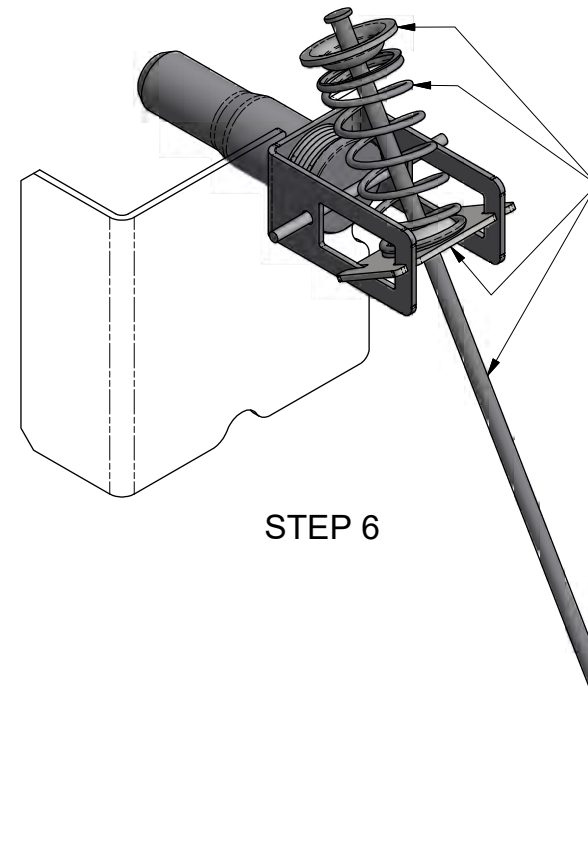

ASSEMBLE SPECIAL WASHER AND PIN ENGAGEMENT SPRING ONTO LINKAGE ROD AND GUIDE THROUGH THE SPRING CAGE PLATE.

STEP 6

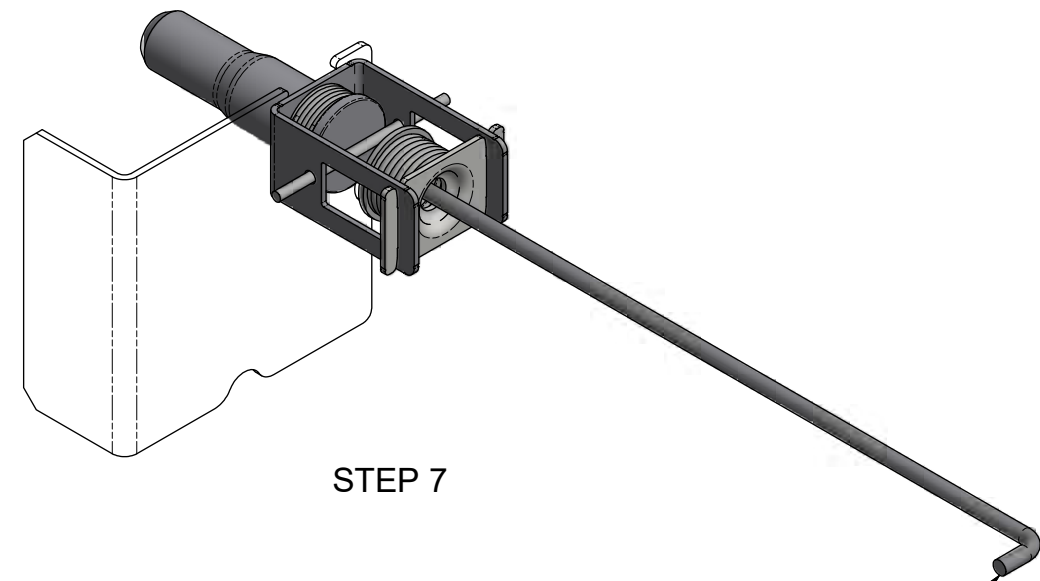

PULL BACK THE LINKAGE ROD. SPRING CAGE PLATE WILL SEAT AGAINST BACK SIDE OF THE SPRING CAGE.

STEP 7

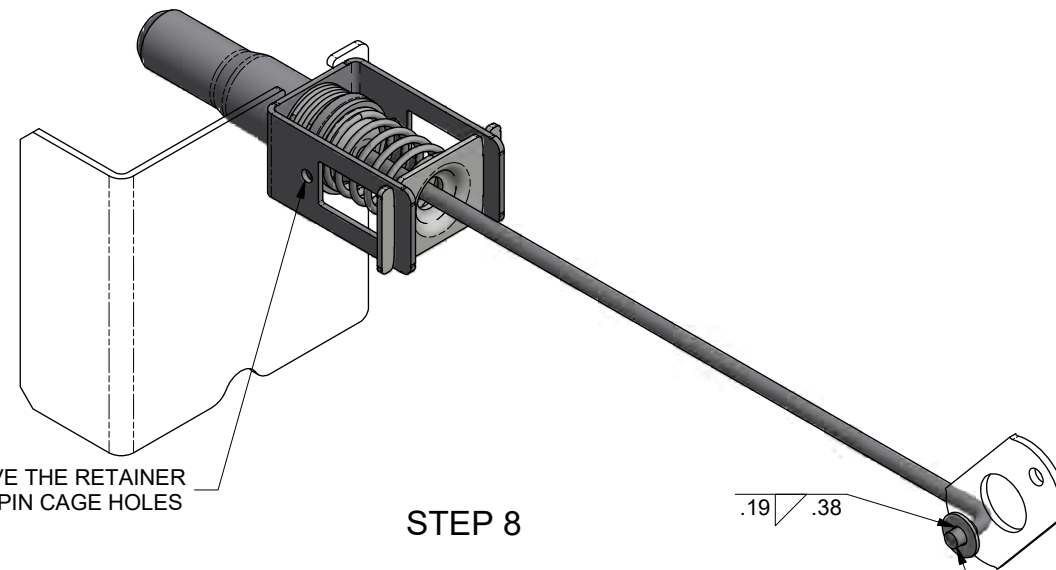

REMOVE THE RETAINER FROM PIN CAGE HOLES

STEP 8

HOOK THE END OF THE LINKAGE ROD THROUGH THE CAM. PLACE THE WASHER ON THE LINKAGE ROD ON THE OPPOSITE SIDE OF THE CAM. WELD THE WASHER ON TO THE LINKAGE ROD.

3. MAKE SURE LOCK PINS EXTEND AND FULLY RETRACT BEFORE PLACING SLIDER IN SERVICE.
2. SLIDER MODEL: MERITOR RHP 11.
1. INSTALLATION INSTRUCTION FOR KIT 29571-01.

NEXT ASSY: NEXT		ER NO.	SYM	REVISIONS			DATE	BY	CHK	APPD	
TOLERANCES (UNLESS OTHERWISE SPECIFIED) DECIMAL .X ± .1 DECIMAL .XX ± .06 DECIMAL .XXX ± .030 ANGULAR ± 1° HOLES: .50 DIA AND LESS: ± .007 .51 DIA AND GREATER: ± .01 REMOVE ALL SHARP BURRS & SHARP CORNERS THAT MIGHT AFFECT ASSEMBLY, APPEARANCE, OR OPERATION OF OUR PRODUCTS.		DRAWN:	ML	DATE:	3/22/2018			HUTCHENS INDUSTRIES, INC. SPRINGFIELD, MISSOURI			
		CHECKED:	JAJ	DATE:	10/4/2018			TITLE: INSTALLATION PROCEUDRE FOR 29571-01 KIT			
		APPROVED:	RSB	DATE:	10/4/2018						
		MFG APPL:	N/A	DATE:	XXXXXX						
		ER:	2018044	DATE:	10/5/2018						
		PROJECT OR FILE REFERENCE NO.:	PROJ#: 20180400								
			EPR#: 20180400-01								
		SCALE:	D SIZE - 1/2 B SIZE - 1/4								
		SHEET 2 OF 2		SIZE:	D	DRAWING NO.:		29563			

This confidential drawing is the property of Hutchens Industries. Hutchens Industries makes no warranties regarding the information on this document. Nothing herein may be transmitted or disclosed in whole or in part to other parties. The recipient of this drawing agrees not to use the information for manufacturing, nor will they modify, distribute, reverse engineer, or create derivative works based on the information contained on this print without the prior written permission of Hutchens Industries. The recipient agrees not to make copies of the document or reproduce in any manner the information in the document and to return it to Hutchens Industries upon request. Any use of this document is acceptance of the terms stated above.
 DRAWING NO. 29563
 REV. 2 OF 2