

This confidential drawing is the property of Hutchens Industries, Hutchens Industries makes no warranties regarding the information on this document. Nothing herein may be transmitted or disclosed in whole or in part to other parties. The recipient of this drawing agrees not use the information for manufacturing, nor will they modify, distribute, reverse engineer, or create derivative works based on the information contained on this print without the prior written permission of Hutchens Industries. The recipient agrees not to make copies of the document or reproduce in any manner the information in the document and to return it to Hutchens Industries upon request. Any use of this document is acceptance of the terms stated above.

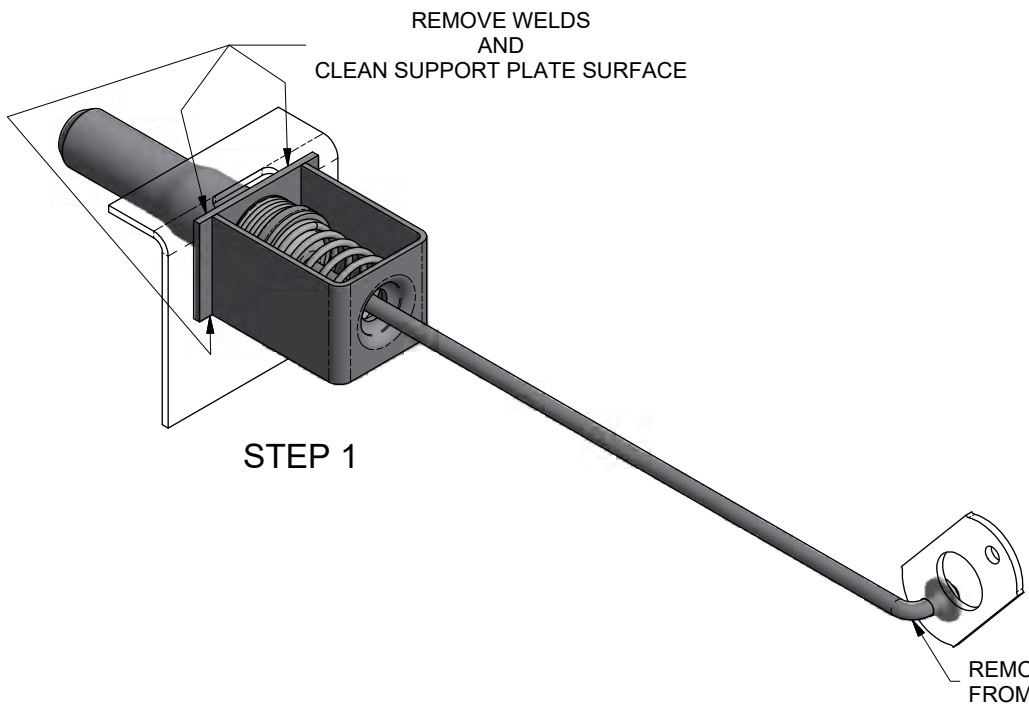

POSITION THE SPRING CAGE. THE LOCK PIN HOLE MUST BE INLINE WITH THE SUPPORT PLATE HOLE.

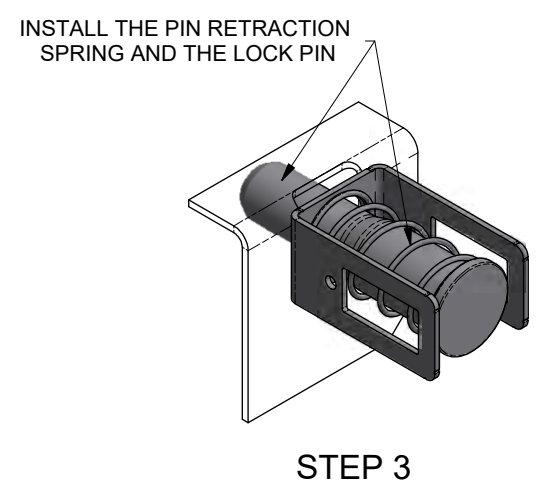
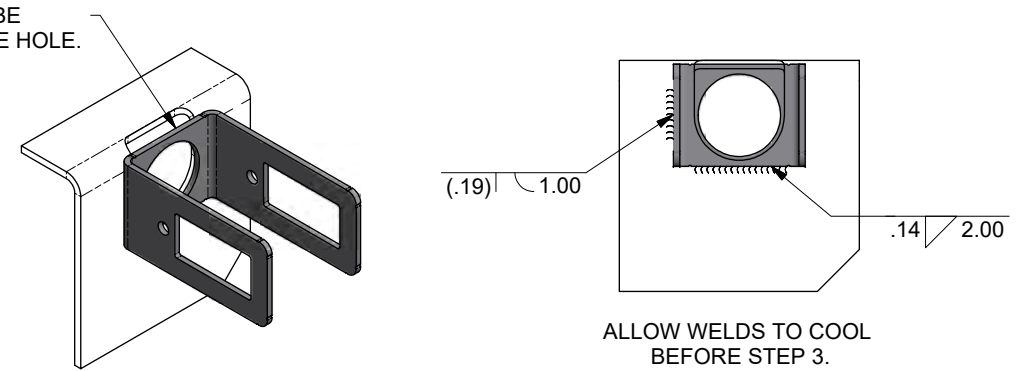

COMPRESS THE LOCK PIN AND RETRACTION SPRING. INSERT A RETAINER ( ROD, SCREWDRIVER, ETC.) THROUGH THE PIN CAGE HOLES.

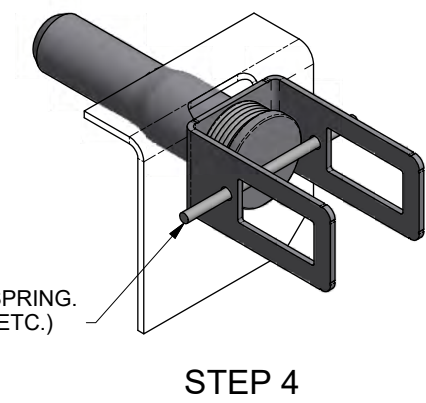

3. MAKE SURE LOCK PINS EXTEND AND FULLY RETRACT BEFORE PLACING SLIDER IN SERVICE.
2. SLIDER MODEL: H9851/H9861.
1. INSTALLATION PROCEDURE FOR KIT 29573-01 AND -02.

NEXT ASSY: NEXT		ER NO.	SYM	DATE	BY	CHK	APPD
TOLERANCES (UNLESS OTHERWISE SPECIFIED)		DRAWN:	ML	3/22/2018			
DECIMAL .X ± .1		CHECKED:	JAJ	10/4/2018			
DECIMAL .XX ± .06		APPROVED:	RSB	10/4/2018			
DECIMAL .XXX ± .030		MFG APPL:	N/A	XXXXXX			
ANGULAR ± 1°		ER:	2018044	10/5/2018			
HOLES:		PROJECT OR FILE REFERENCE NO.	PROJ#: 20180400				
.50 DIA AND LESS: ± .007		EPR#:	20180400-01				
.51 DIA AND GREATER: ± .01		SCALE:	D SIZE - 1/2				
REMOVE ALL SHARP BURRS & SHARP CORNERS THAT MIGHT AFFECT ASSEMBLY, APPEARANCE, OR OPERATION OF OUR PRODUCTS.			B SIZE - 1/4				
		SHEET 1 OF 2		SIZE:	DRAWING NO.: 29685		
				REV.	1 OF 2		



HUTCHENS INDUSTRIES, INC.  
SPRINGFIELD, MISSOURI

INSTALLATION PROCEDURE FOR 29573-01, -02 KIT

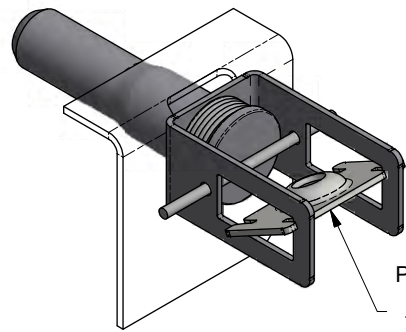

POSITION THE SPRING CAGE PLATE BETWEEN THE RECTANGULAR SLOTS IN THE SPRING CAGE.

STEP 5

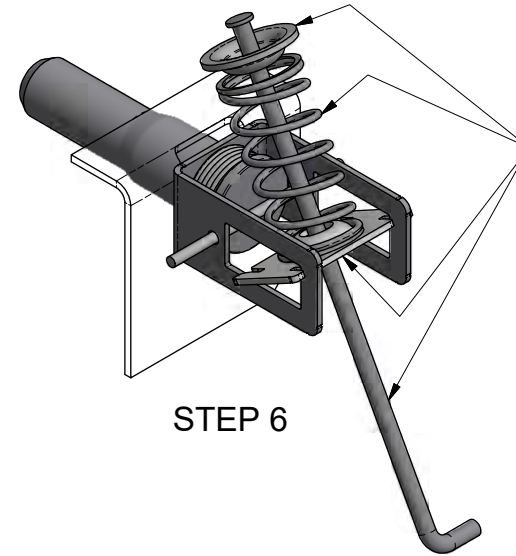

ASSEMBLE SPECIAL WASHER AND PIN ENGAGEMENT SPRING ONTO LINKAGE ROD AND GUIDE THROUGH THE SPRING CAGE PLATE.

STEP 6

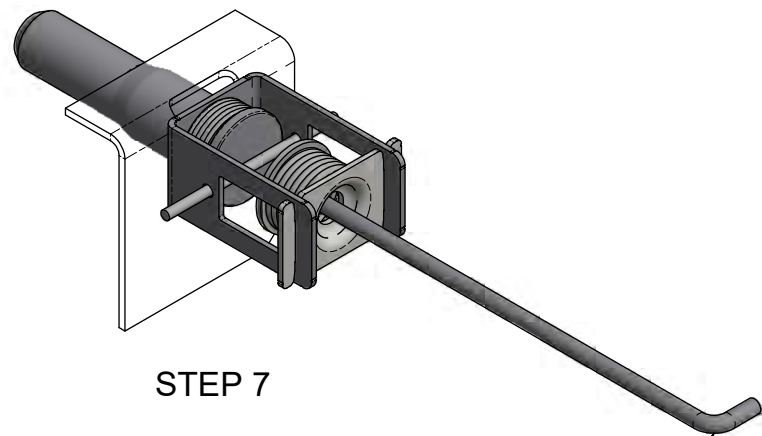

PULL BACK THE LINKAGE ROD. SPRING CAGE PLATE WILL SEAT AGAINST BACK SIDE OF THE SPRING CAGE.

STEP 7

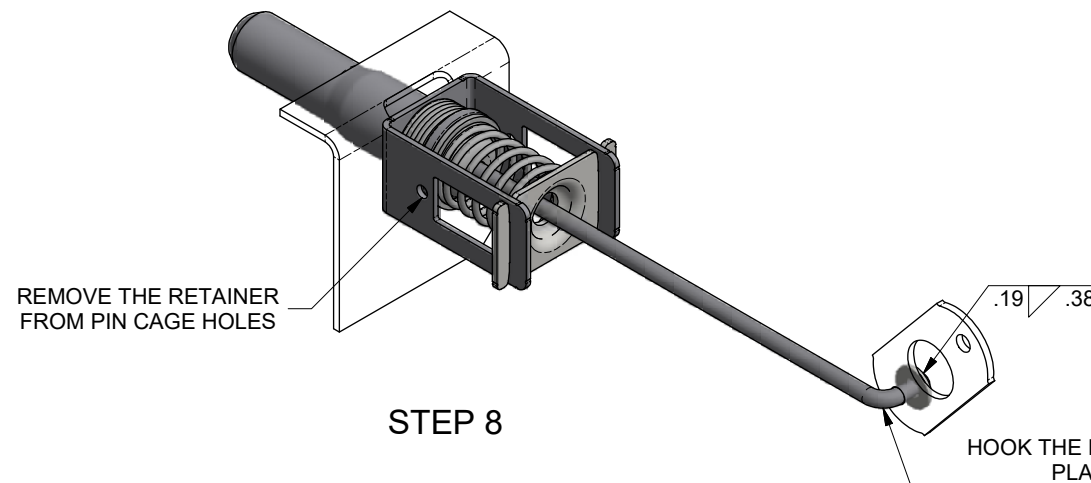

REMOVE THE RETAINER FROM PIN CAGE HOLES

HOOK THE END OF THE LINKAGE ROD THROUGH THE CAM. PLACE THE WASHER ON THE LINKAGE ROD ON THE OPPOSITE SIDE OF THE CAM. WELD THE WASHER ON TO THE LINKAGE ROD.

STEP 8

3. MAKE SURE LOCK PINS EXTEND AND FULLY RETRACT BEFORE PLACING SLIDER IN SERVICE.
2. SLIDER MODEL: H9851/H9861.
1. INSTALLATION PROCEDURE FOR KIT 29573-01 AND -02.

NEXT ASSY: NEXT		ER NO.	SYM	DATE	BY	CHK	APPD
TOLERANCES (UNLESS OTHERWISE SPECIFIED)		DRAWN:	ML	3/22/2018			
DECIMAL .X ± .1		CHECKED:	JAJ	10/4/2018			
DECIMAL .XX ± .06		APPROVED:	RSB	10/4/2018			
DECIMAL .XXX ± .030		MFG APPL:	N/A	XXXXXX			
ANGULAR ± 1°		ER:	2018044	10/5/2018			
HOLES:		PROJECT OR FILE REFERENCE NO.:	PROJ#: 20180400				
.50 DIA AND LESS: ± .007		SCALE:	EPR#: 20180400-01				
.51 DIA AND GREATER: ± .01		D SIZE - 1/2	SHEET 2 OF 2				
REMOVE ALL SHARP BURRS & SHARP CORNERS THAT MIGHT AFFECT ASSEMBLY, APPEARANCE, OR OPERATION OF OUR PRODUCTS.		B SIZE - 1/4	DRAWING NO.: 29685				
				HUTCHENS INDUSTRIES, INC. SPRINGFIELD, MISSOURI			
				TITLE: INSTALLATION PROCEDURE FOR 29573-01, -02 KIT			
						REV. 2 OF 2	

This confidential drawing is the property of Hutchens Industries. Hutchens Industries makes no warranties regarding the information on this document. Nothing herein may be transmitted or disclosed in whole or in part to other parties. The recipient of this drawing agrees not to use the information for manufacturing, nor will they modify, distribute, reverse engineer, or create derivative works based on the information contained on this print without the prior written permission of Hutchens Industries. The recipient agrees not to make copies of the document or reproduce in any manner the information in the document and to return it to Hutchens Industries upon request. Any use of this document is acceptance of the terms stated above.

DRAWING NO. 29685

REV. 2 OF 2