

REMOVE WELDS
CLEAN CROSSMEMBER AND
SIDE RAIL SURFACE

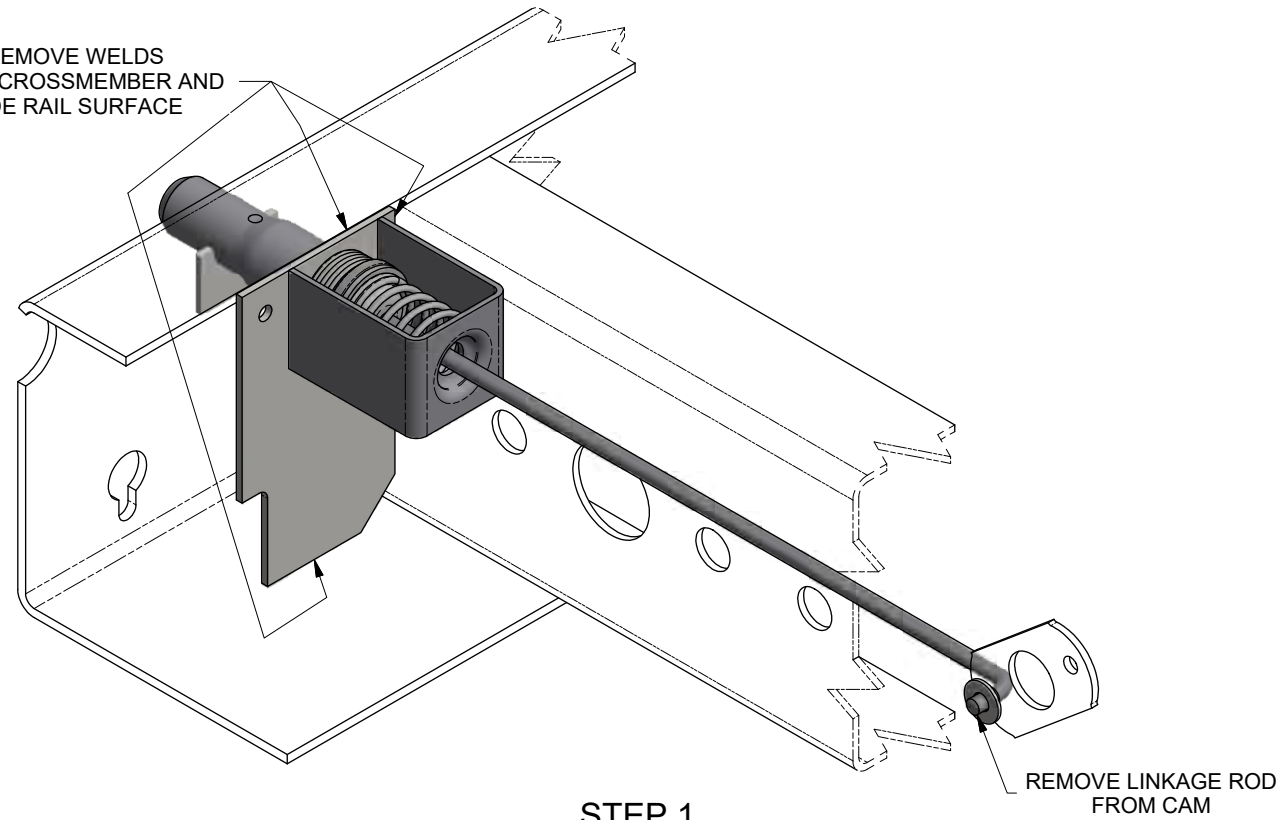

STEP 1

REMOVE LINKAGE ROD
FROM CAM

POSITION THE SPRING CAGE PLATE ASSEMBLY.
SPRING CAGE PLATE SHALL ATTACH TO
CROSSMEMBER AND SIDE RAIL.

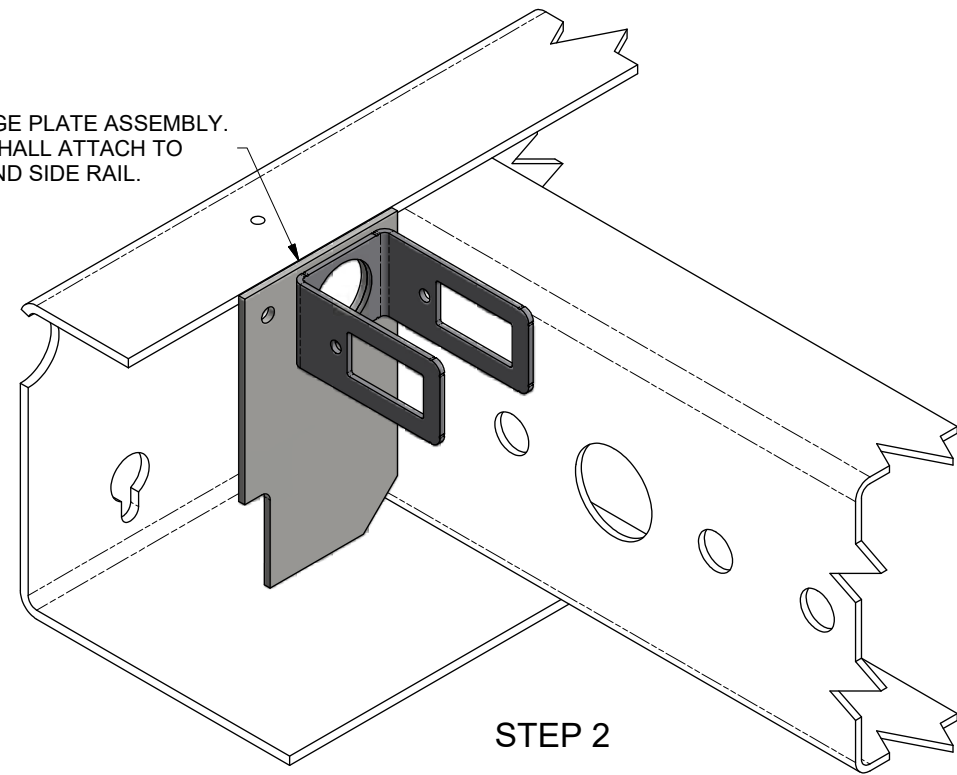

STEP 2

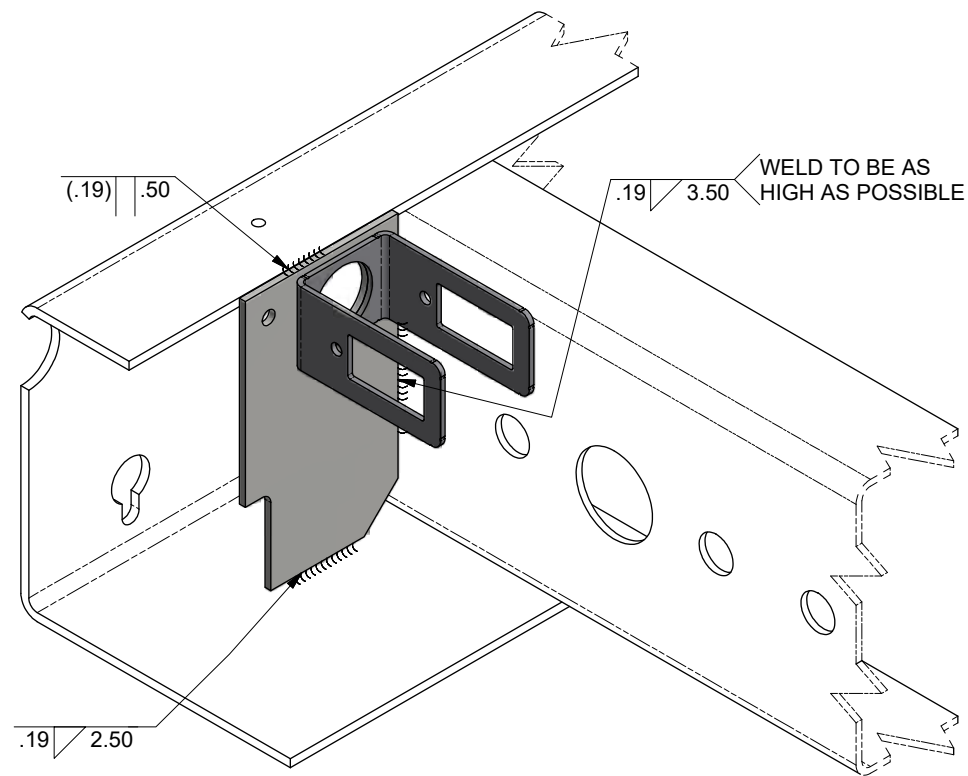

ALLOW WELDS TO COOL
BEFORE STEP 4.

STEP 3

WELD TO BE AS
HIGH AS POSSIBLE

INSTALL THE PIN RETRACTION
SPRING AND THE LOCK PIN

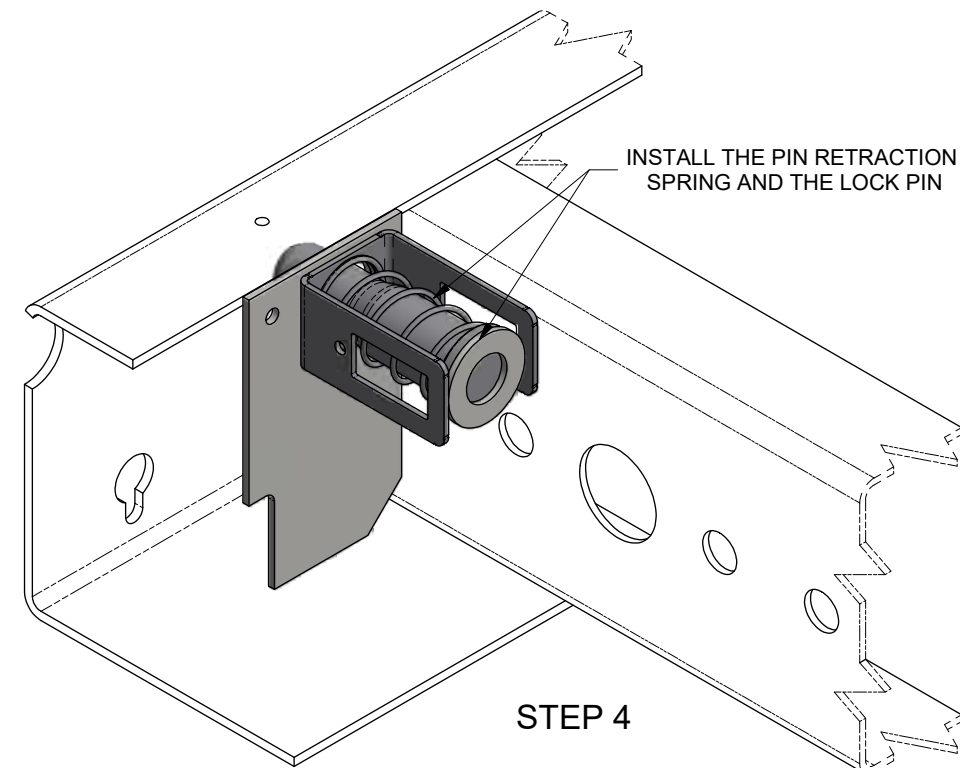

STEP 4

3. MAKE SURE LOCK PINS EXTEND AND FULLY RETRACT BEFORE PLACING SLIDER IN SERVICE.
2. SLIDER MODEL: DANA ADVANTAGE SLIDER BINKLEY STYLE FRONT PIN.
1. INSTALLATION PROCEDURE FOR KIT 29571-06 AND -07.

NEXT ASSY: NEXT		ER NO.	SYM	REVISIONS		DATE	BY	CHK	APPD
TOLERANCES (UNLESS OTHERWISE SPECIFIED) DECIMAL .X ± .1 DECIMAL .XX ± .06 DECIMAL .XXX ± .030 ANGULAR ± 1° HOLES: .50 DIA AND LESS: ± .007 .51 DIA AND GREATER: ± .01 REMOVE ALL SHARP BURRS & SHARP CORNERS THAT MIGHT AFFECT ASSEMBLY, APPEARANCE, OR OPERATION OF OUR PRODUCTS.		DRAWN:	ML	DATE:	3/22/2018	 HUTCHENS INDUSTRIES, INC. SPRINGFIELD, MISSOURI			
		CHECKED:	JAJ	DATE:	10/4/2018				
		APPROVED:	RSB	DATE:	10/4/2018				
		MFG APPL:	N/A	DATE:	XX/XX/XX				
		ER:	2018044	DATE:	10/5/2018	TITLE: INSTALLATION PROCEDURE FOR 29571-06, -07 KIT			
		PROJECT OR FILE REFERENCE NO. PROJ#: 20180400 EPR#: 20180400-01		SCALE: D SIZE - 1/2 B SIZE - 1/4		SHEET 1 OF 3		SIZE: D	DRAWING NO.: 29713
								REV.	1 OF 3

This confidential drawing is the property of Hutchens Industries, Hutchens Industries makes no warranties regarding the information on this document. Nothing herein may be transmitted or disclosed in whole or in part to other parties. The recipient of this drawing agrees not use the information for manufacturing, nor will they modify, distribute, reverse engineer, or create derivative works based on the information contained on this print without the prior written permission of Hutchens Industries. The recipient agrees not to make copies of the document or reproduce in any manner the information in the document and to return it to Hutchens Industries upon request. Any use of this document is acceptance of the terms stated above.

COMPRESS THE LOCK PIN AND RETRACTION SPRING.
INSERT A RETAINER (ROD, SCREWDRIVER, ETC.)
THROUGH THE PIN CAGE HOLES.

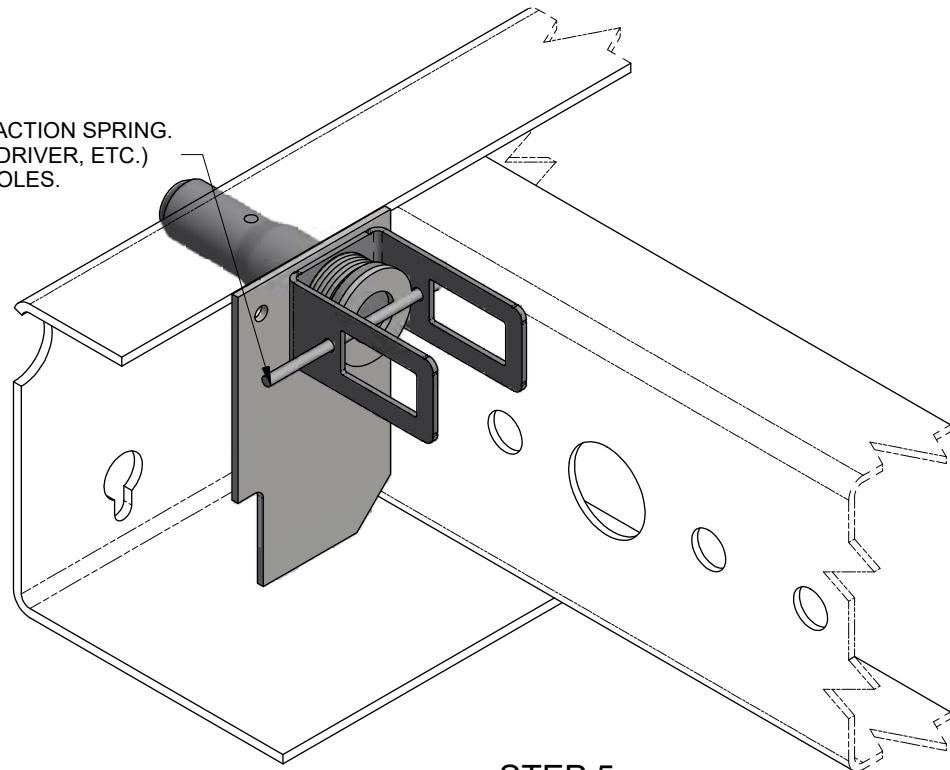

STEP 5

POSITION THE SPRING CAGE
PLATE BETWEEN
THE RECTANGULAR SLOTS
IN THE SPRING CAGE.

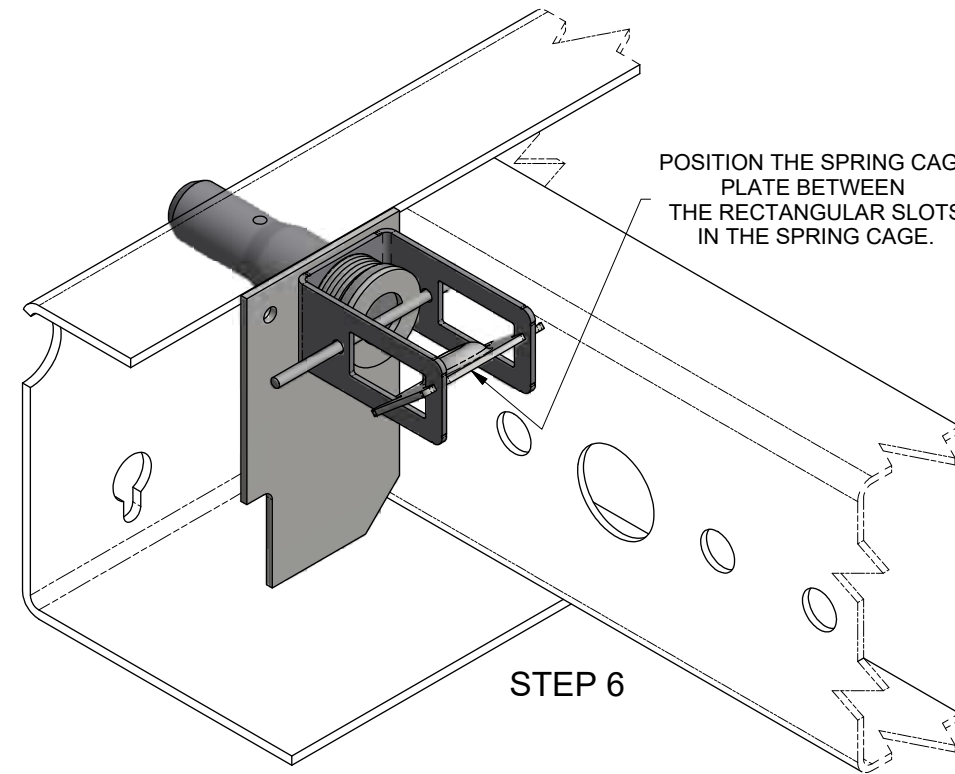

STEP 6

ASSEMBLE SPECIAL WASHER
AND PIN ENGAGEMENT SPRING
ONTO LINKAGE ROD
AND GUIDE THROUGH THE SPRING CAGE PLATE.

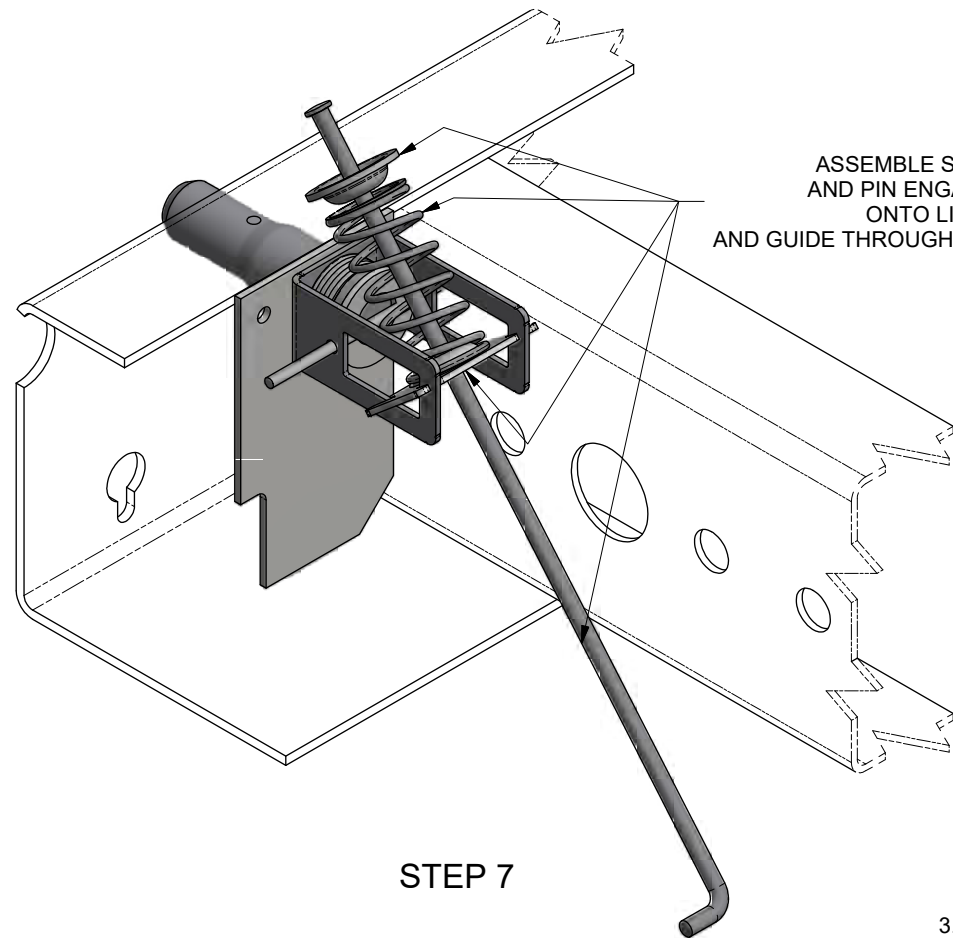

STEP 7

STEP 8

PULL BACK THE LINKAGE ROD.
SPRING CAGE PLATE WILL SEAT AGAINST
BACK SIDE OF THE SPRING CAGE.

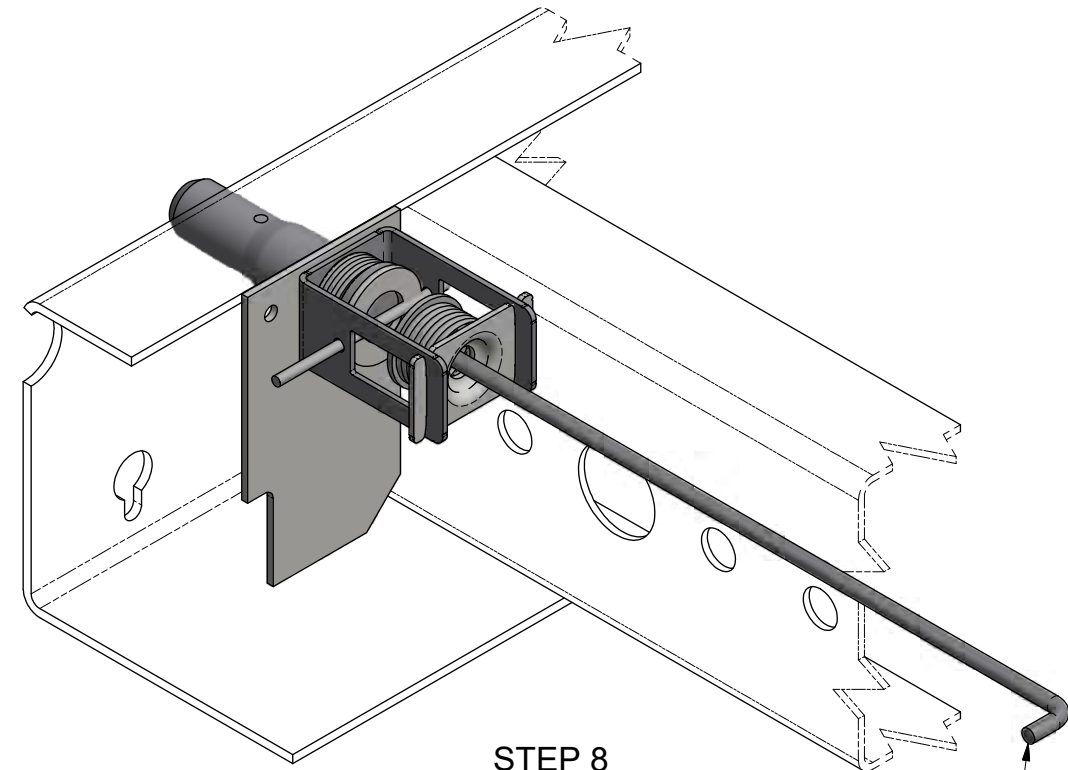

3. MAKE SURE LOCK PINS EXTEND AND FULLY
RETRACT BEFORE PLACING SLIDER IN SERVICE.

2. SLIDER MODEL: DANA ADVANTAGE SLIDER BINKLEY STYLE FRONT PIN.

1. INSTALLATION PROCEDURE FOR KIT 29571-06 AND -07.

NEXT ASSY: NEXT		ER NO.	SYM	DATE	BY	CHK	APPD
TOLERANCES (UNLESS OTHERWISE SPECIFIED) DECIMAL .X ± .1 DECIMAL .XX ± .06 DECIMAL .XXX ± .030 ANGULAR ± 1°		DRAWN:	ML	3/22/2018			
HOLES: .50 DIA AND LESS: ± .007 .51 DIA AND GREATER: ± .01 REMOVE ALL SHARP BURRS & SHARP CORNERS THAT MIGHT AFFECT ASSEMBLY, APPEARANCE, OR OPERATION OF OUR PRODUCTS.		CHECKED:	JAJ	10/4/2018			
SCALE: D SIZE - 1/2 B SIZE - 1/4		APPROVED:	RSB	10/4/2018			
PROJECT OR FILE REFERENCE NO. PROJ#: 20180400 EPR#: 20180400-01		MFG APPL:	N/A	DATE: XX/XX/XX			
DRAWING NO. 29713		ER:	2018044	DATE: 10/5/2018			
HUTCHENS INDUSTRIES, INC. SPRINGFIELD, MISSOURI		TITLE: INSTALLATION PROCEDURE FOR 29571-06, -07 KIT		SHEET 2 OF 3		SIZE: D	DRAWING NO.: 29713
REV. 2 OF 3							

This confidential drawing is the property of Hutchens Industries, Hutchens Industries makes no warranties regarding the information on this document. Nothing herein may be transmitted or disclosed in whole or in part to other parties. The recipient of this drawing agrees not to use the information for manufacturing, nor will they modify, distribute, reverse engineer, or create derivative works based on the information contained on this print without the prior written permission of Hutchens Industries. The recipient agrees not to make copies of the document or reproduce in any manner the information in the document and to return it to Hutchens Industries upon request. Any use of this document is acceptance of the terms stated above. DRAWING NO. 29713

This confidential drawing is the property of Hutchens Industries, Hutchens Industries makes no warranties regarding the information on this document. Nothing herein may be transmitted or disclosed in whole or in part to other parties. The recipient of this drawing agrees not use the information for manufacturing, nor will they modify, distribute, reverse engineer, or create derivative works based on the information contained on this print without the prior written permission of Hutchens Industries. The recipient agrees not to make copies of the document or reproduce in any manner the information in the document and to return it to Hutchens Industries upon request. Any use of this document is acceptance of the terms stated above.

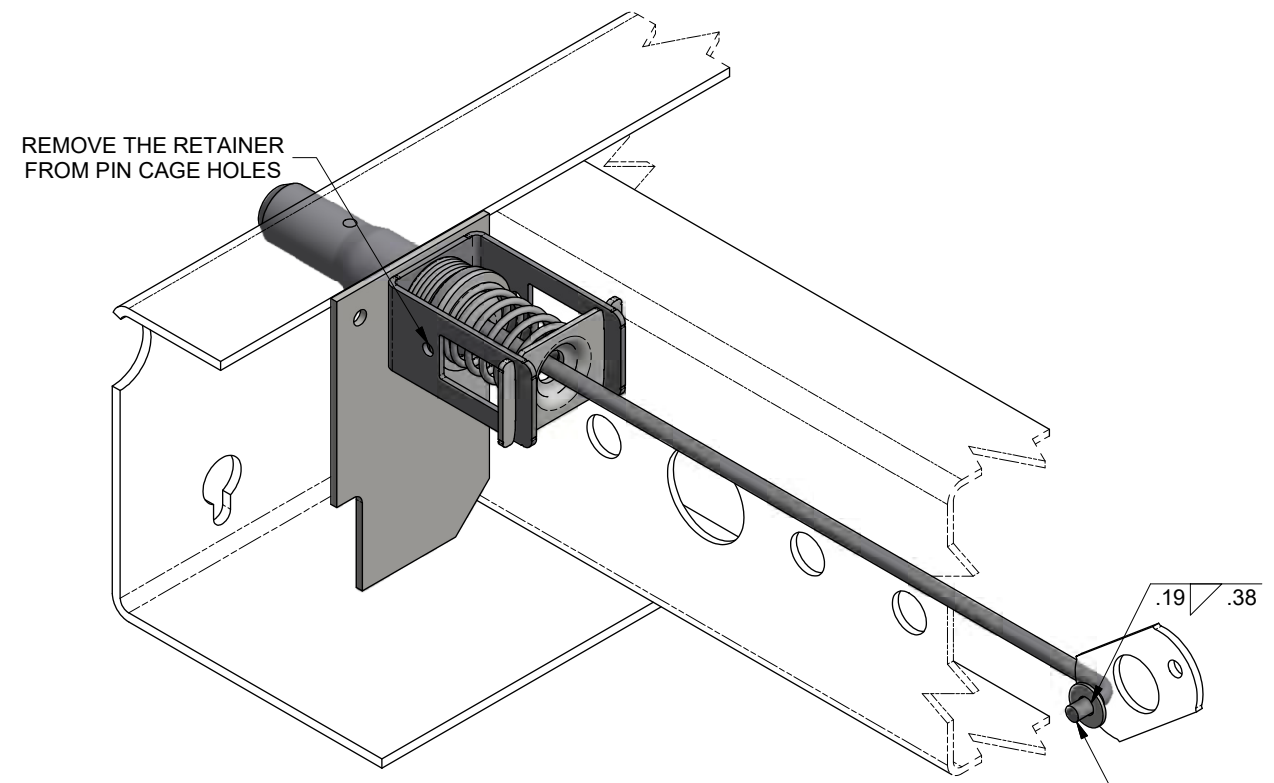

REMOVE THE RETAINER FROM PIN CAGE HOLES

STEP 9

HOOK THE END OF THE LINKAGE ROD THROUGH THE CAM.
 PLACE THE WASHER ON THE LINKAGE ROD ON THE OPPOSITE SIDE OF THE CAM.
 WELD THE WASHER ON TO THE LINKAGE ROD.

3. MAKE SURE LOCK PINS EXTEND AND FULLY RETRACT BEFORE PLACING SLIDER IN SERVICE.
2. SLIDER MODEL: DANA ADVANTAGE SLIDER BINKLEY STYLE FRONT PIN.
1. INSTALLATION PROCEDURE FOR KIT 29571-06 AND -07.

NEXT ASSY: NEXT		ER NO.	SYM	REVISIONS				DATE	BY	CHK	APPD						
TOLERANCES (UNLESS OTHERWISE SPECIFIED) DECIMAL .X ± .1 DECIMAL .XX ± .06 DECIMAL .XXX ± .030 ANGULAR ± 1° HOLES: .50 DIA AND LESS: ± .007 .51 DIA AND GREATER: ± .01 REMOVE ALL SHARP BURRS & SHARP CORNERS THAT MIGHT AFFECT ASSEMBLY, APPEARANCE, OR OPERATION OF OUR PRODUCTS.		DRAWN:	ML	DATE:	3/22/2018				HUTCHENS INDUSTRIES, INC. SPRINGFIELD, MISSOURI								
		CHECKED:	JAJ	DATE:	10/4/2018												
		APPROVED:	RSB	DATE:	10/4/2018		TITLE: INSTALLATION PROCEDURE FOR 29571-06, -07 KIT										
		MFG APPL:	N/A	DATE:	XX/XX/XX												
		ER:	2018044	DATE:	10/5/2018												
PROJECT OR FILE REFERENCE NO.		PROJ#:		20180400		EPR#:		20180400-01		SCALE:	D SIZE - 1/2 B SIZE - 1/4	SHEET 3 OF 3	SIZE: D	DRAWING NO.:	29713	REV.:	3 OF 3