

This confidential drawing is the property of Hutchens Industries. Hutchens Industries makes no warranties regarding the information on this document. Nothing herein may be transmitted or disclosed in whole or in part to other parties. The recipient of this drawing agrees not to use the information for manufacturing, nor will they modify, distribute, reverse engineer, or create derivative works based on the information contained on the print without the prior written permission of Hutchens Industries. The recipient agrees not to make copies of the document or reproduce in any manner the information in the document and to return it to Hutchens Industries upon request. Any use of this document is acceptance of the terms stated above.

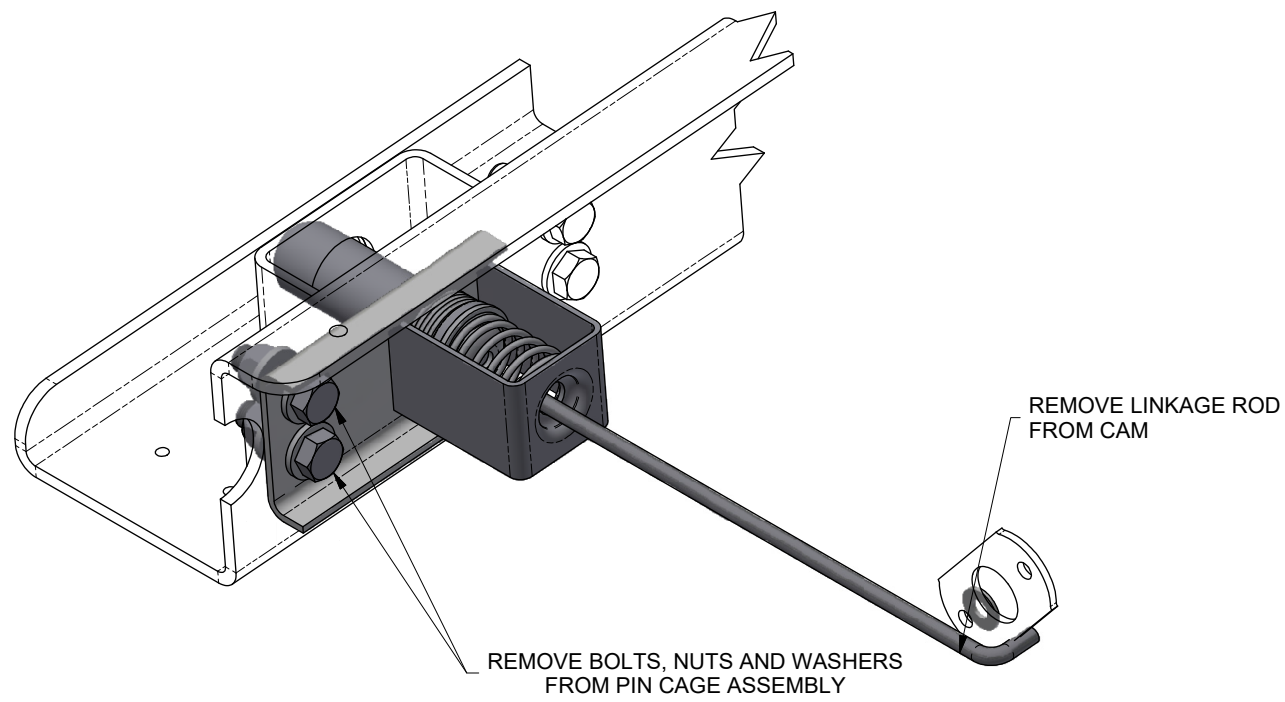

REMOVE BOLTS, NUTS AND WASHERS FROM PIN CAGE ASSEMBLY

REMOVE LINKAGE ROD FROM CAM

STEP 1

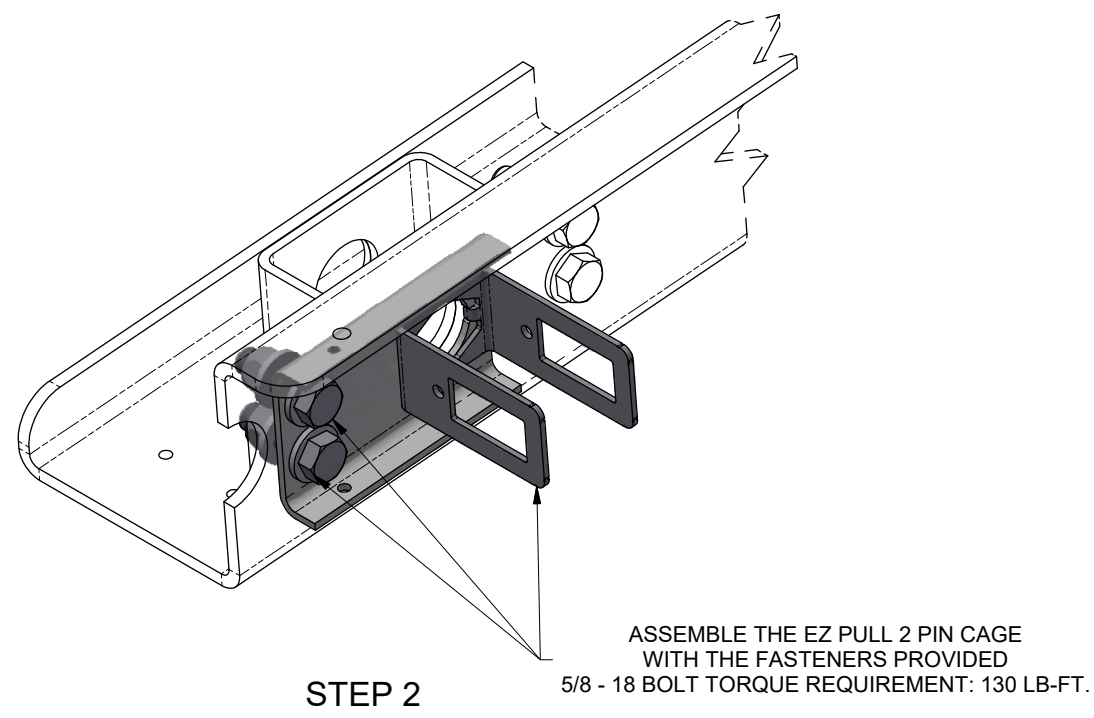

ASSEMBLE THE EZ PULL 2 PIN CAGE WITH THE FASTENERS PROVIDED
5/8 - 18 BOLT TORQUE REQUIREMENT: 130 LB-FT.

STEP 2

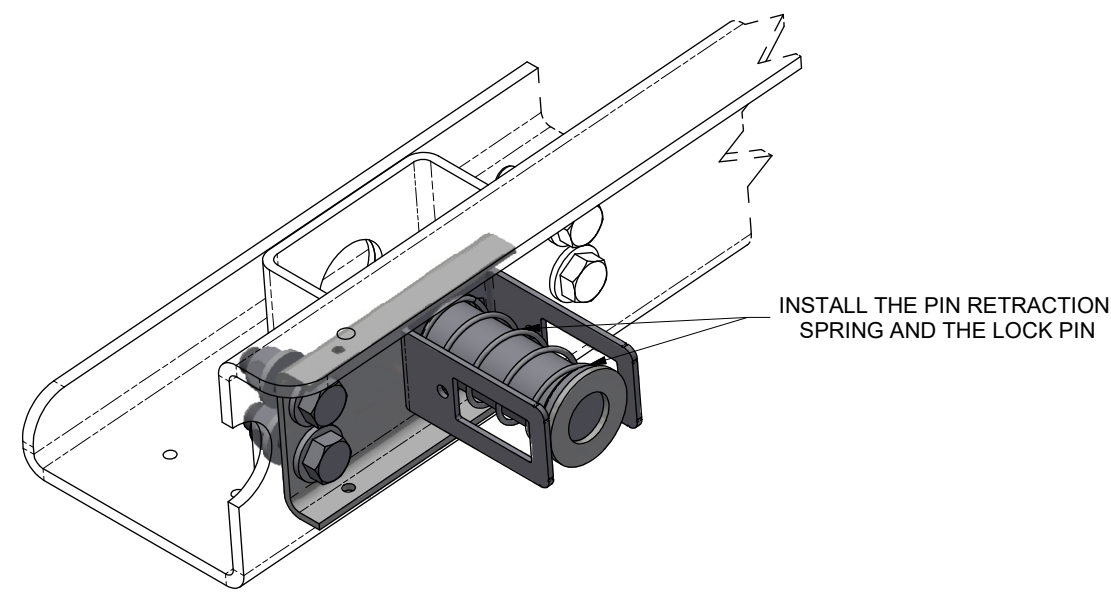

INSTALL THE PIN RETRACTION SPRING AND THE LOCK PIN

STEP 3

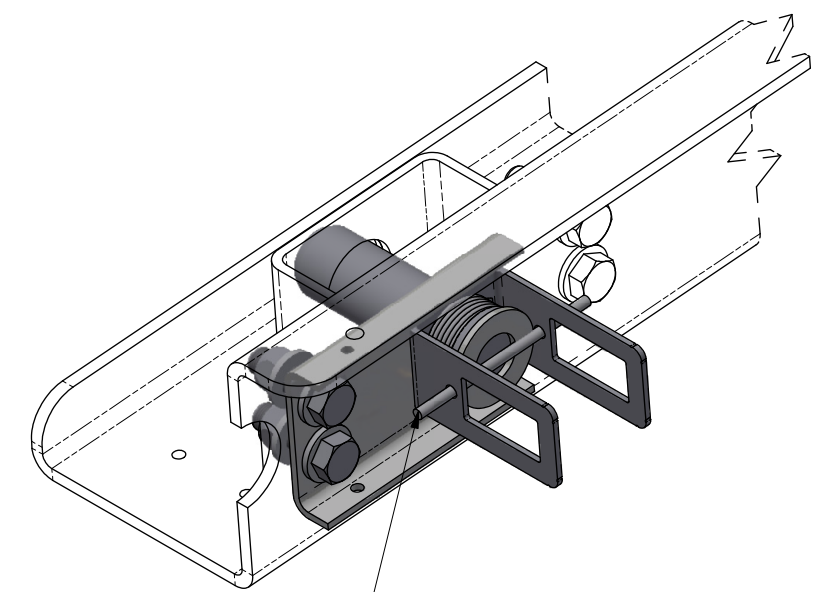

COMPRESS THE LOCK PIN AND RETRACTION SPRING. INSERT A RETAINER (ROD, SCREWDRIVER, ETC.) THROUGH THE PIN CAGE HOLES.

STEP 4

- 3. MAKE SURE LOCK PINS EXTEND AND FULLY RETRACT BEFORE PLACING SLIDER IN SERVICE.
- 2. SLIDER MODEL: 44" IBC Z-FRAME SLIDE.
- ① 1. INSTALLATION PROCEDURE FOR KIT 29574-01, -02, AND -03.

2022142	B	REVISED NOTE 1, ADDED KIT NO. 29574-03.	12/22	JAJ	BWH	DAC
2019111	A	PICTORIALLY REVISED THE VIEWS TO SHOW THE CORRECT ORIENTATION OF THE SLIDER AND PIN CAGES.	06/19	CBB	JAJ	RSB
ER NO.	SYM	REVISIONS	DATE	BY	CHK	APPD
DRAWN: ML		DATE: 3/22/2018	HUTCHENS INDUSTRIES, INC. SPRINGFIELD, MISSOURI			
CHECKED: JAJ		DATE: 10/4/2018				
APPROVED: RSB		DATE: 10/4/2018	INSTALLATION PROCEDURE FOR 29574-01, -02, -03 KIT			
MFG APPL: N/A		DATE: XXXXXX				
ER: 2018044		DATE: 10/5/2018	SHEET 1 OF 2			
PROJECT OR FILE REFERENCE NO. PROJ#: 20180400 EPR#: 20180400-01		SCALE: D SIZE - 1/2 B SIZE - 1/4				
TOLERANCES (UNLESS OTHERWISE SPECIFIED) DECIMAL .X ± .1 DECIMAL .XX ± .06 DECIMAL .XXX ± .030 ANGULAR ± 1° HOLES: .50 DIA AND LESS: ± .007 .51 DIA AND GREATER: ± .01 REMOVE ALL SHARP BURRS & SHARP CORNERS THAT MIGHT AFFECT ASSEMBLY, APPEARANCE, OR OPERATION OF OUR PRODUCTS.		DRAWING NO. 29719		REV. B		1 OF 2

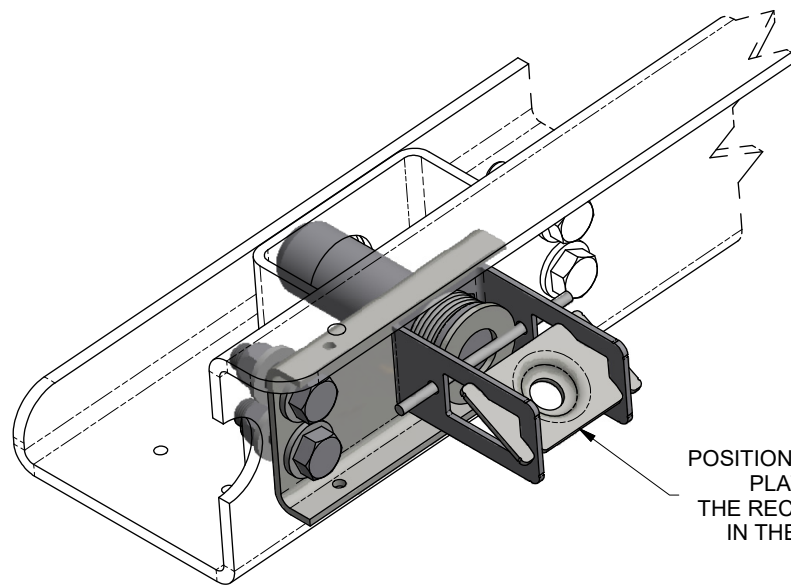

POSITION THE SPRING CAGE
PLATE BETWEEN
THE RECTANGULAR SLOTS
IN THE SPRING CAGE.

STEP 5

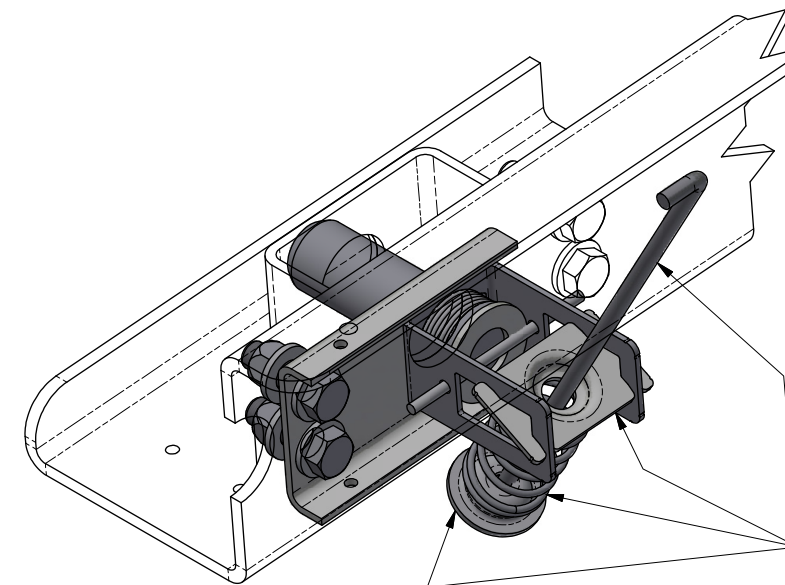

ASSEMBLE SPECIAL WASHER
AND PIN ENGAGEMENT SPRING
ONTO LINKAGE ROD
AND GUIDE THROUGH THE SPRING CAGE PLATE.

STEP 6

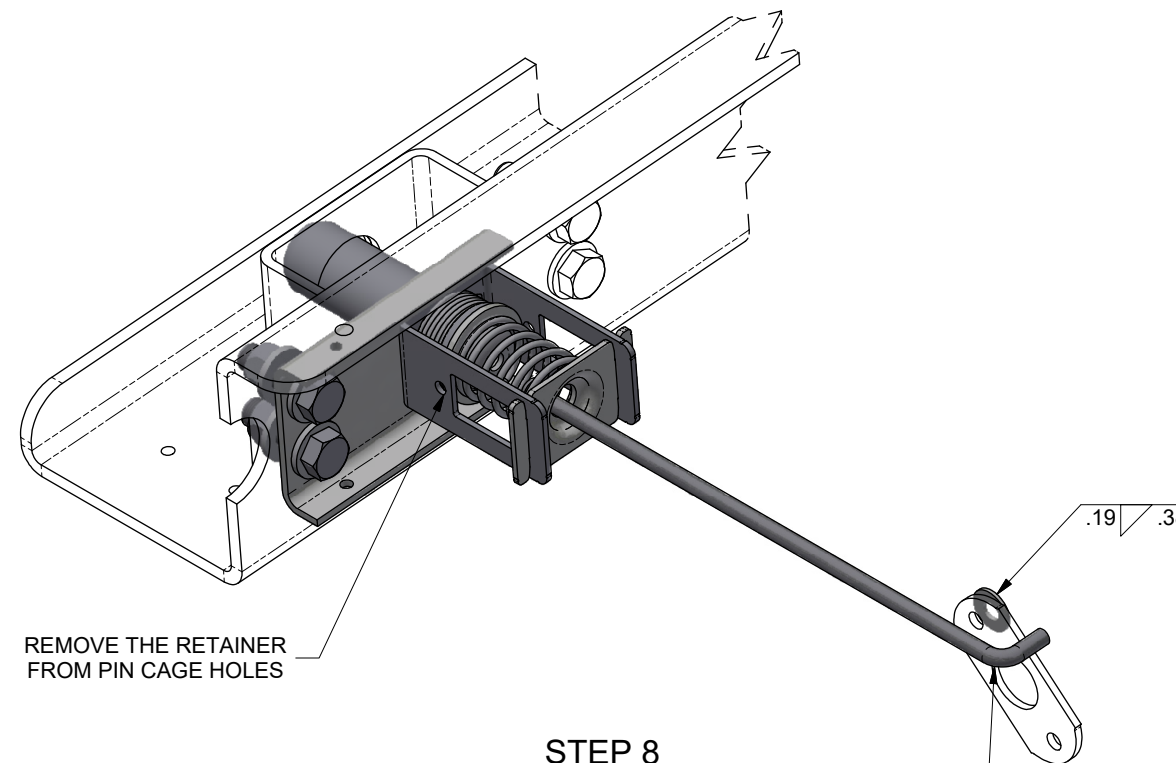

REMOVE THE RETAINER
FROM PIN CAGE HOLES

HOOK THE END OF THE LINKAGE ROD THROUGH THE CAM.
PLACE THE WASHER ON THE LINKAGE ROD
ON THE OPPOSITE SIDE OF THE CAM.
WELD THE WASHER ON TO THE LINKAGE ROD.

STEP 8

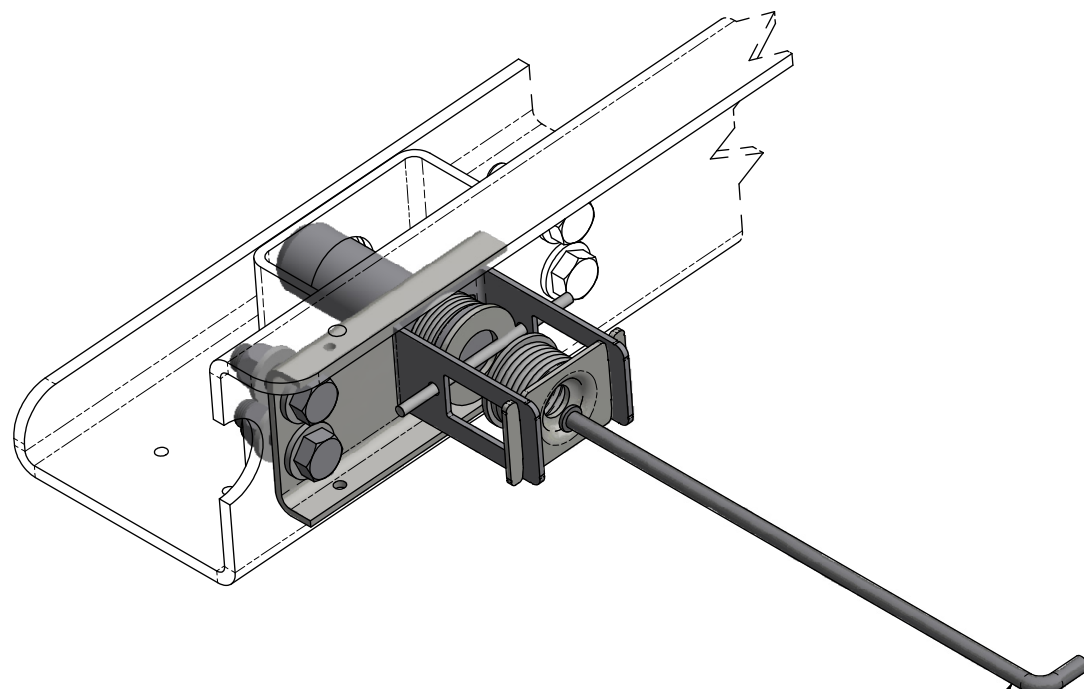

PULL BACK THE LINKAGE ROD.
SPRING CAGE PLATE WILL SEAT AGAINST
BACK SIDE OF THE SPRING CAGE.

STEP 7

3. MAKE SURE LOCK PINS EXTEND AND FULLY RETRACT BEFORE PLACING SLIDER IN SERVICE.
2. SLIDER MODEL: 44" IBC Z-FRAME SLIDE.
- ① 1. INSTALLATION PROCEDURE FOR KIT 29574-01, -02, AND -03.

2022142	B	REVISED NOTE 1, ADDED KIT NO. 29574-03.	12/22	JAJ	BWH	DAC
2019111	A	PICTORIALLY REVISED THE VIEWS TO SHOW THE CORRECT ORIENTATION OF THE SLIDERAIL AND PIN CAGES.	06/19	CBB	JAJ	RSB
ER NO.	SYM	REVISIONS	DATE	BY	CHK	APPD
DRAWN: ML		DATE: 3/22/2018				
CHECKED: JAJ		DATE: 10/4/2018				
APPROVED: RSB		DATE: 10/4/2018	HUTCHENS INDUSTRIES, INC. SPRINGFIELD, MISSOURI			
MFG APPL: N/A		DATE: XXXXXX				
ER: 2018044		DATE: 10/5/2018	INSTALLATION PROCEDURE FOR 29574-01, -02, -03 KIT			
PROJECT OR FILE REFERENCE NO. PROJ#: 20180400		EPR#: 20180400-01				
SCALE: D SIZE - 1/2		SHEET 2 OF 2	SIZE: D	DRAWING NO.: 29719		REV. B
B SIZE - 1/4						2 OF 2

This confidential drawing is the property of Hutchens Industries, Inc. Hutchens Industries makes no warranties regarding the information on this drawing. Nothing herein may be transmitted or disclosed in whole or in part to other parties. The recipient of this drawing agrees not to use the information for manufacturing, nor will they modify, distribute, reverse engineer, or create derivative works based on the information contained on the print without the prior written permission of Hutchens Industries, Inc. The recipient agrees not to make copies of the document or reproduce in any manner the information in the document and to return it to Hutchens Industries upon request. Any use of this document is acceptance of the terms stated above.