

**The World's Leading  
Manufacturer Of Trailer Sliders  
For Over Six Decades.**

**8500**



**Slider Series**

# **Parts & Installation**



## **Hutchens Industries**

**The Difference is Durability. The Quality is Hutchens.**

Springfield, MO ■ (800) 654-8824 ■ (417) 862-5012  
Fax (417) 862-2317 ■ [www.hutchensindustries.com](http://www.hutchensindustries.com)

Copyright © 2026 Hutchens Industries

# 8500 Slider Series

## Application

The 8500 sidemount friction slider is specially designed for platform trailers and similar applications where a mounting height approximating that of a standard spring suspension without a slider is desired. This slider is especially well suited for use with I-beam type frames. The 8500 slider utilizes Hutchens sidemount hangers and is only supplied with hangers and pipe braces attached.

## Capacity

Consistent with Hutchens suspensions, the 8500's gross axle weight rating (G.A.W.R.) is limited to a maximum of 25,000 lbs./axle.

## Features

- ▶ A spring loaded, positive locking-pin mechanism utilizing forged lock pins.
- ▶ Sturdy sidemount hangers attached to the slider frame resulting in a reduction of the distance from top of hanger to top of body rail to 9/16 of an inch.

- ▶ Structural angle body rails provide strength as well as a wide bearing surface.
- ▶ Minimum width for maximum tire clearance, and extra crossmembers and gussets for increased strength.
- ▶ Adjustable in 4 inch increments allowing precise variations in vehicle weight distribution while providing the wheel base best suited to your needs.
- ▶ Hutch's locator bar; the best compromise in weight and strength. Solid steel plugs welded at each end of a steel tube bar make repositioning fast and easy.

## Options

The 8500 slider may be ordered with various spring center dimensions to accommodate different trailer frame widths. The slider is furnished with 192" body rails. Other lengths up to 252" are available upon request. Widespreads and tri-axles are also available.

## How To Order Your 8500 Slider Assembly

All Hutch sliders designed for platform trailer applications are provided with hangers and pipe braces attached. Unlike our other sliders that are designed for van trailer applications, *the 8500 model slider is ordered by spring centers as opposed to frame width.*

1. Calculate what spring centers (SC) you intend to use. This measurement is generally the same as the measurement between the centerlines of the I-beam frame. **See Fig. 1.**
2. Select the range of slide adjustment you need and determine what body rail length will provide that range. **See Chart B.**
3. A locator bar assembly is a standard component with every Hutchens slider. See Chart C. The locator bar should be used as directed when positioning the slider. **See "To Position The Sliding Suspension."**
4. Since the Hutchens product line is not based on an alphanumeric numbering system, each slider must be ordered by a description of the slider.

### Example:

An 8500 slider with 38" spring centers, 9700T sidemount hangers and pipe braces attached, 192" body rails, and a locator bar assembly would be ordered as follows:

Quantity	Model	Spring Centers	Body Rail Length
1 ea.	8500	38"	192"
			w/ Locator Bar
			<i>w/ 9700T sidemount hangers attached*</i>

\* If you are ordering a complete suspension with the slider, a description of the unit must follow (i.e. 3/4" seats for 5" round axles, less standard 3 leaf springs with 7040-08 U-bolts).

Fig. 1

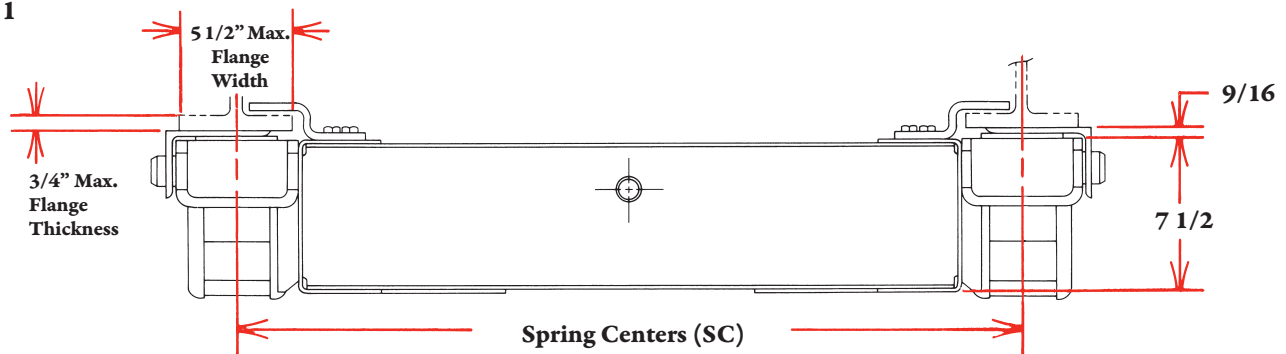



# 8500

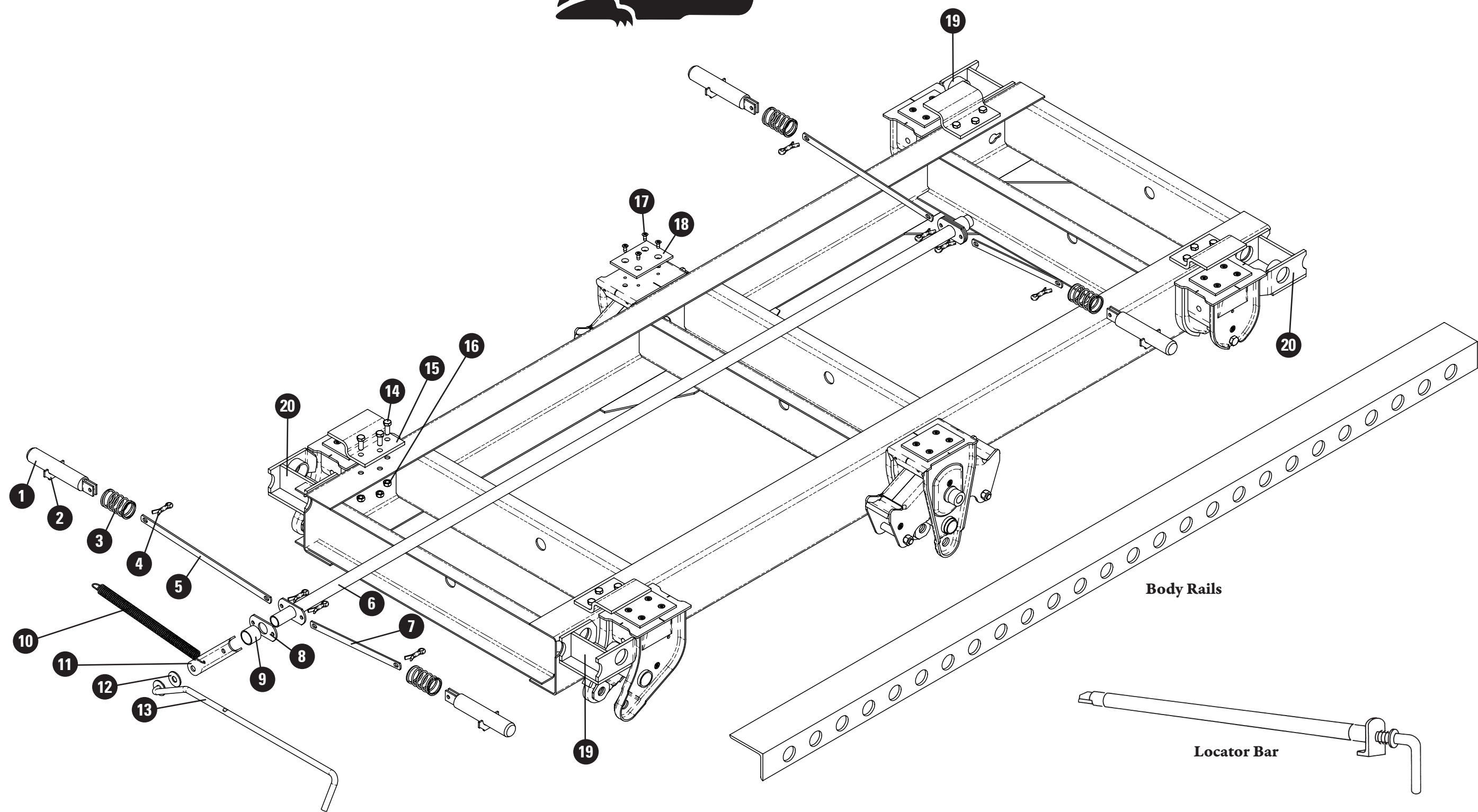

## Bill of Materials

The items listed below are for use with an 8500 model slider having a standard axle spacing of 49".

Item	Part No.	Quantity	Description
1	11410-02	4	Lock Pin Assembly – 9.19" LG
2	11414-00	4	Special Half Washer
3	8098-01	4	Compression Spring – Lock Pin, PL
4	8016-00	8	Cotter Pin - .375" x 1.25"
5	See Chart A	2	Link (varies with frame width)
6	8010-17	1	Pipe – 1" STD x 105"
7	11412-03	2	Link – 13.62" OAL
8	8028-00	4	Cam – Puller Kit
9	405-72	2	Pipe – 1.25" STD x 1.38"
10*	8018-01	1	Spring - Helex, 12 GA x 1 PD x 8 5/8"
	8018-02	1	Spring - Helex, 12 GA x 1 PD x 10 1/8"
11	8026-00	1	Crank - Puller Kit
12	8054-00	3	Plain Washer - 5/8"
13	8518-00	1	Pull Handle - 28" LG
14	8040-00	12	Hex Cap Screw – 1/2" - 20 UNF x 1 1/4" LG, GR5
15	8505-00	4	Slider Hold Down – Zee, .375" x 6"
16	28692-01	12	Hex Lock Nut – 1/2" - 20 UNF - 2B, GRB - Coated
17	9627-00	24	Th'd Form Screw – 5/16" - 18 x 3/4", CSHD
18	12818-01	6	Slider Pad – 1/4" x 4" x 5 1/2", UHMW
19	8511-01	2	Cage Assembly – Lock Pin, LH
20	8511-02	2	Cage Assembly – Lock Pin, RH

\* Note: For units with spring centers of 38" and less use the 8018-01  
For units with spring centers greater than 38" use the 8018-02

## Chart A - Link (Item #7)

Part No.	Spring Centers	Overall Length (OAL)
11412-08	36"	11.62"
11412-02	37"	12.62"
11412-03	38"	13.62"
11412-05	42"	17.62"
11412-16	43"	18.62"
11412-06	44"	19.62"

## Chart B - Body Rail Assemblies

Part No.	Length	Nominal Adj.
8178-01	176"	64"
8178-02	192"	80"
8178-03	216"	104"
8178-04	240"	128"
8178-05	168"	56"
8178-06	228"	116"
8178-07	200"	88"

## Chart C - Locator Bar Assemblies

Part No.	Spring Centers
11641-02	36"
11641-04	37"
11641-05	38"
11641-10	42"
11641-06	43"
11641-07	44"

# Installation



## Hangers:

Fabricated sidemount hangers are installed by Hutchens as an integral part of the 8500 slider, and are located, as depicted for 49" axle centers only, by the following sketch.

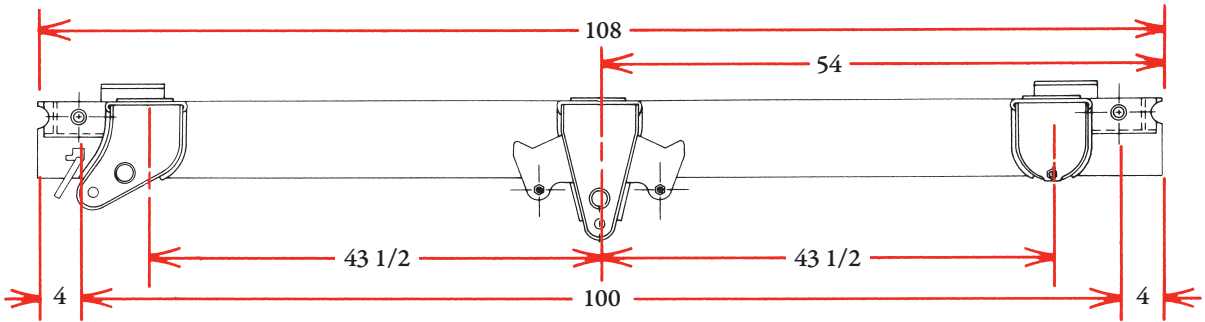

NOTE: The installer will be responsible for adequate tire clearance both vertically and laterally.

## Body Rails:

1. Determine the location of the body rails.

- For sliders with standard axle spacings of 49" and widespreads with axle spacings through 81", this is accomplished by measuring out from the centerline of the trailer a distance equal to one-half of the spring centers and adding 3 inches. This locates the inside of the body rail. This measurement should be performed at the front and rear of each body rail. See Fig. 2.

Fig. 2  
(49" A/C - 81" A/C)

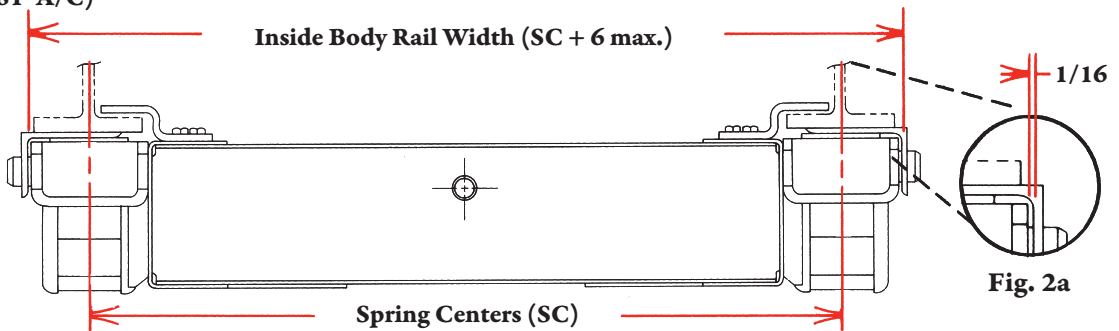

- For widespread sliders with axle spacings of 97" through 121", body rail location is accomplished by measuring out from the centerline of the trailer a distance equal to one-half of the spring centers and adding 3 9/16 inches. This measurement should be performed at the front and rear of each body rail. See Fig. 3.

Fig. 3  
(97" A/C - 121" A/C)

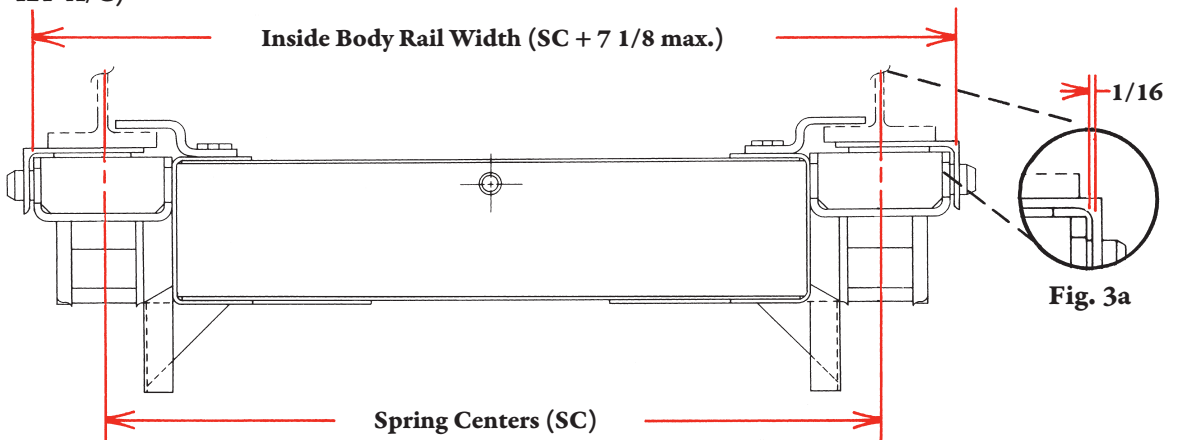

## Body Rails: (con't)

2. Clamp the body rails in position under the trailer.
  - a) When locating body rails on the trailer frame flange, it is helpful if the slider lock pins are centered in the body rail holes on both sides. The same clearance should be maintained around the complete lock pin circumference in order to ensure easy operation of the lock pins.
  - b) To ensure optimum slider performance, body rails should be shimmed out from the four corners of the lower slide unit 1/16 of an inch. See Figs. 2a and 3a. Check the spacing of the body rails by moving slider the length of the body rails with shims in place.

3. Weld the body rails securely to the underside of the trailer.

4. Remove shims and check unit for free operation along the entire length of the body rails.

NOTE: Each trailer manufacturer may have their own preferred method of effecting body rail alignment and attachment.

5. On all sliders the trailer structure must block the front and rear rail openings to prevent the slider frame from escape. See Fig. 4.

Fig. 4

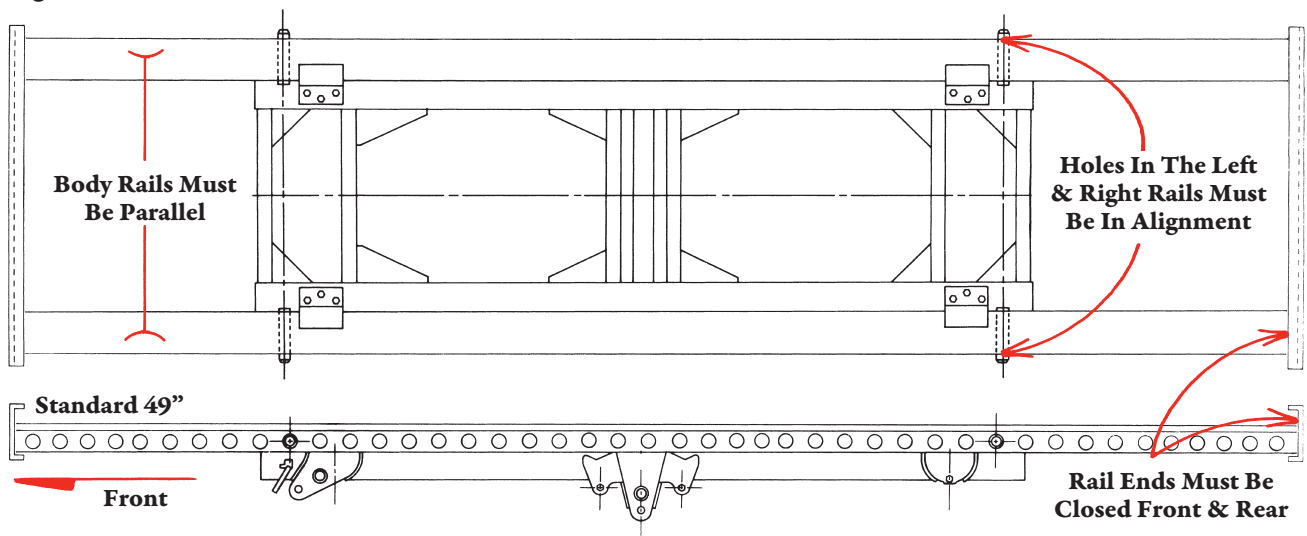

## Hold Down Clips:

6. Secure the hold down clips at each corner of the slider assembly. Each clip requires two 1/2" diameter bolts and lock nuts, which are furnished by Hutchens. Tighten the nuts and bolts to 65-78 lb-ft (lubricated/coated), 85-102 lb-ft (dry) torque.

## Suspension Alignment:

ALIGNMENT CAN ONLY BE ACHIEVED IF THE LOCKPIN HOLES ARE EVENLY LOCATED FROM THE KINGPIN, LEFT AND RIGHT. ALIGNMENT SHOULD ALWAYS BE DONE WHILE THE TRAILER IS EMPTY.

To properly align the suspension attached to your 8500 slider, the trailer should be pulled in a straight line a sufficient distance to ensure there are no binds in the suspension. The trailer should then be pulled straight forward with the trailer brakes locked, so the locking pins rest against the rear of the holes in the body rails. This approximates the position of the pins when the trailer is being pulled on a highway, and ensures proper trailer tracking. Alignment can be achieved with an optical device especially for this purpose, or manually in the following manner.

- a) Measure the distance from the kingpin to the centerline of the spindles on the front axles. It is recommended that spindle extensions be utilized. As noted in Fig. 5, dimensions A and B must be equal within 1/8 of an inch. Alignment is accomplished by loosening the torque arm clamp bolts on both ends of the adjustable torque arm and turning the adjustment screw as required.

Fig. 5

$$A = B \pm 1/8$$

$$C = D \pm 1/16$$

$$E \leq 1/4$$

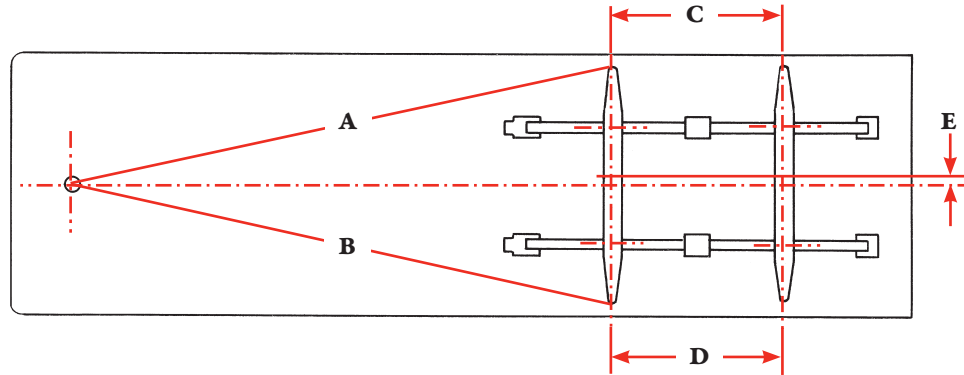

b) After the front axle is aligned, tighten the 5/8" torque arm clamp bolts to 130-156 lb-ft (lubricated/coated), 170-204 lb-ft (dry) torque in order to lock the position of this axle. Next, align any succeeding axles with the front axle following the same procedure.

- ▶ Loosen the torque arm clamp bolts, turn the adjustment screw until dimensions C and D are equal within 1/16" of each other, then tighten the clamp bolts to the proper torque.
- ▶ Check dimension E, the lateral centerline relationship of the trailer body and axles. If E exceeds 1/4", contact the trailer manufacturer for recommendations.
- ▶ After alignment has been completed on all axles, all 5/8" torque arm clamp bolts should be rechecked to make certain that they are tightened to the necessary 130-156 lb-ft (lubricated/coated), 170-204 lb-ft (dry) torque.
- ▶ Relocate the slider to the forward position and recheck the kingpin alignment. Variance in A and B dimensions would indicate lock pin hole discrepancies.
- ▶ Refer to Truck Trailer Manufacturers (TTMA) Recommended Practice RP No. 71 and The Maintenance Council (TMC) Recommended Practice RP708D for more details.

### To Position The Sliding Suspension:

1. Set both the tractor and trailer brakes.
2. Remove the locator bar from behind the slider and move to desired location.
3. To release the lock pins, pull the operating handle all the way out and lock in place.
4. Release the tractor brakes and carefully drive forward or backward until the sliding suspension is at the desired location.
5. Release the operating handle and visually check all lock pins for locking. The main body of each lock pin must extend through the holes in the rails.
6. Lock the locator bar in both rails immediately behind the slider.
7. With the trailer brakes applied, gently rock the trailer backward and forward to ensure the sliding suspension is properly locked, and follow the procedures set out above before pulling the trailer. The lock pins must be checked at each stop to ensure each is locked.

### Important: Warning Decal Note

When the installation of your "Hutch" slider is complete and the trailer and/or subframe has been painted, the decal (shown here) must be installed in plain view on the road side of the trailer immediately above the suspension. The decal must be in plain view on each trailer equipped with a "Hutch" slider, and must be read before using the sliding suspension. Decals are shipped with the slider units. If decals are not received, or if for any reason additional decals are wanted, contact our Customer Service Department at (417) 862-5012 or fax (417) 862-2317 and decals will be shipped promptly at no charge.

**WARNING**

FAILURE TO LOCK THE SLIDING SUSPENSION CAN CAUSE A LOSS OF VEHICLE CONTROL, DEATH, SERIOUS BODILY INJURY, AND PROPERTY DAMAGE.

Hutchens Slider Series (Decal Part Number 16088-01 Rev. E)

THIS TRAILER IS EQUIPPED WITH A SLIDING SUSPENSION THAT MUST BE SECURELY LOCKED PRIOR TO OPERATION. THE SLIDING SUSPENSION IS LOCKED WHEN THE MAIN BODY OF EACH LOCK PIN EXTENDS THROUGH THE HOLES IN THE RAILS. BEFORE PULLING THE TRAILER, THE SLIDING SUSPENSION MUST BE CAREFULLY INSPECTED TO ENSURE IT IS PROPERLY POSITIONED AND THE MAIN BODY OF EACH LOCK PIN DOES EXTEND THROUGH THE HOLE IN THE RAILS. BEFORE PULLING THE TRAILER, APPLY TRAILER BRAKES AND GENTLY ROCK TRAILER BACKWARDS AND FORWARDS TO ENSURE SLIDING SUSPENSION IS SECURE.

TO POSITION THE SLIDING SUSPENSION:

1. Set both tractor and trailer brakes.
2. Remove locator bar from behind slider and move to desired location.
3. To release the lock pins, pull operating handle all the way out and lock in place.
4. Release the tractor brakes and carefully drive forward or backward until the sliding suspension is at the desired location.
5. Release operating handle and visually check all lock pins for locking. The main body of each lock pin must extend through the holes in the rails.
6. Lock locator bar in both body rails immediately behind slider.
7. With the trailer brakes applied, gently rock trailer backward and forward to ensure sliding suspension is properly locked and follow procedures set out above before pulling the trailer. The lock pins must be checked at each stop to ensure each is locked.

**Hutchens Industries, Inc., P.O. Box 1427, Springfield, Missouri 65801-1427 Toll Free 1 (800) 654-8824**