

HUTCHENS INDUSTRIES INC.

ROCKER IDENTIFICATION

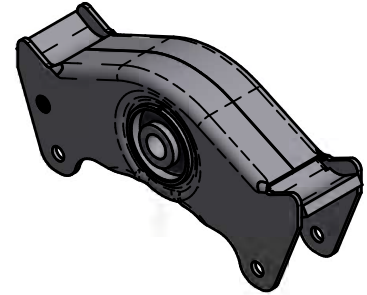

LENGTH	HOLE CENTERS	MODEL NO. (BUSHING TYPE)	PART NO.	COMMENTS
16.50	11.75	9700 (ONE BOLT)	16158-01	49" AXLE CENTERS FABRICATED
16.50	11.75	7700 (TWO BOLT)	750-03	49" AXLE CENTERS FABRICATED

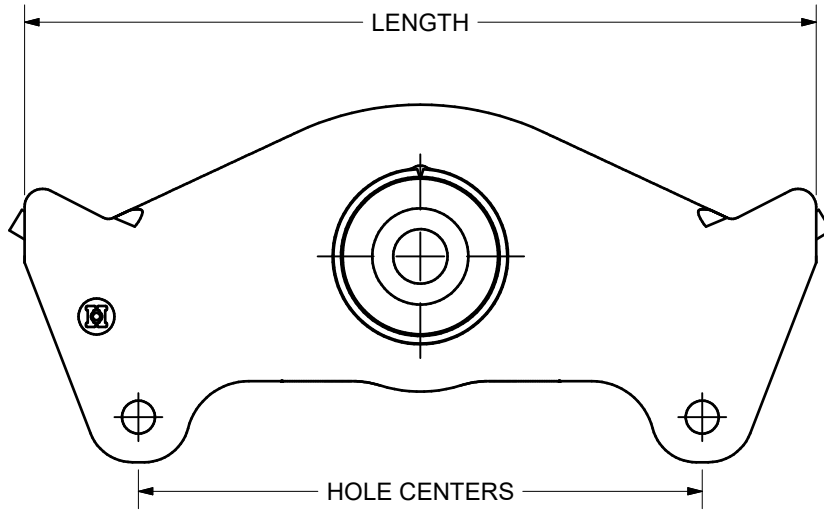
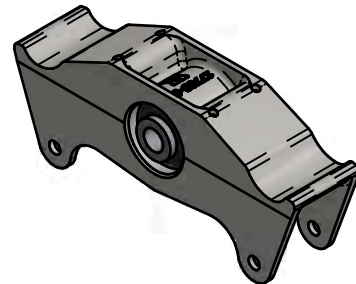
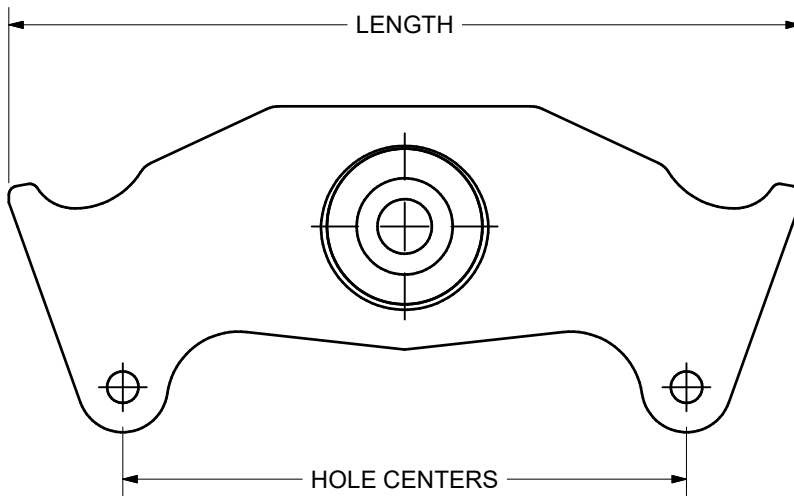

LENGTH	HOLE CENTERS	MODEL NO. (BUSHING TYPE)	PART NO.	COMMENTS
16.50	11.75	9700 (ONE BOLT)	17784-01	49" AXLE CENTERS CAST
16.50	11.75	7700 (TWO BOLT)	19137-01	49" AXLE CENTERS CAST

ROCKER IDENTIFICATION	ER: 2005122	REV: G	SHEET: 1 OF 7
	PROJ#: 20050500	REV DATE: 12/11/19	
		REV ER: 2019254	DRAWING NO.: 23663

HUTCHENS INDUSTRIES INC.

ROCKER IDENTIFICATION

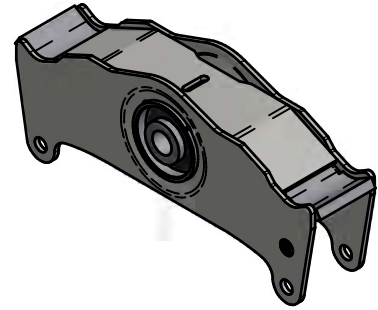
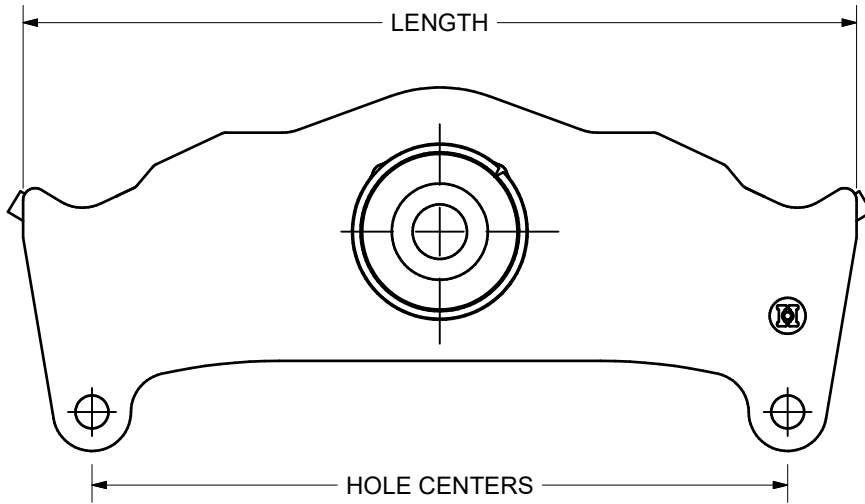

LENGTH	HOLE CENTERS	MODEL NO. (BUSHING TYPE)	PART NO.	COMMENTS
17.38	14.50	9700 (ONE BOLT)	24711-01	44/50/51 AXLE CENTERS FABRICATED
1738	14.50	7700 (TWO BOLT)	24712-01	44/50/51 AXLE CENTERS FABRICATED

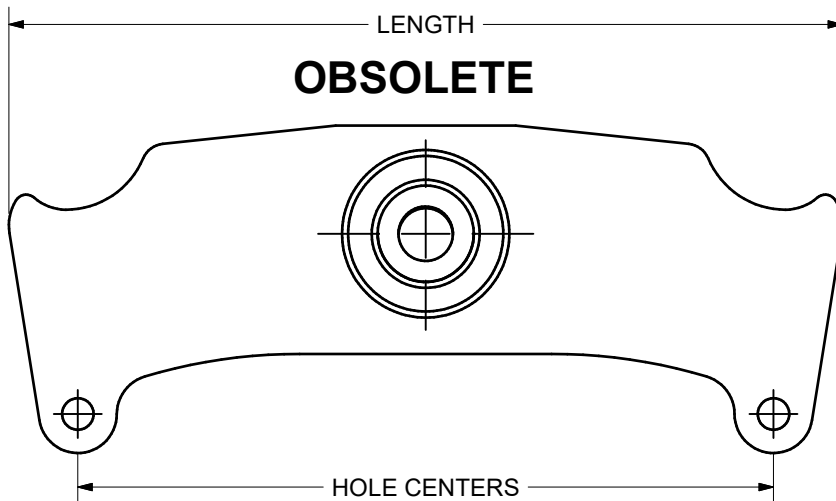

PART NUMBERS ARE GIVEN FOR REFERENCE ONLY USE THE 24711-01 AND 24712-01 FABRICATED VERSIONS

LENGTH	HOLE CENTERS	MODEL NO. (BUSHING TYPE)	PART NO.	COMMENTS
17.38	14.50	9700 (ONE BOLT)	16189-01	44" AXLE CENTERS, CAST 50/51 AC
		7700 (TWO BOLT)	7750-02	
17.38	14.88	9700 (ONE BOLT)	16159-03 (OBS) USE 16159-01	44" AXLE CENTERS SINGLE LEAF SPRING, CAST. OBSOLETE, USE 14.51 HOLE CTRS
		7700 (TWO BOLT)	10283-02 (OBS) USE 7750-02	

ROCKER IDENTIFICATION	ER: 2005122	REV: G	SHEET: 2 OF 7
		REV DATE: 12/11/19	
	PROJ#: 20050500	REV ER: 2019254	DRAWING NO.: 23663

HUTCHENS INDUSTRIES INC.

ROCKER IDENTIFICATION

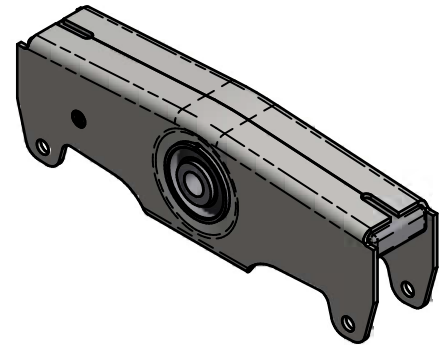
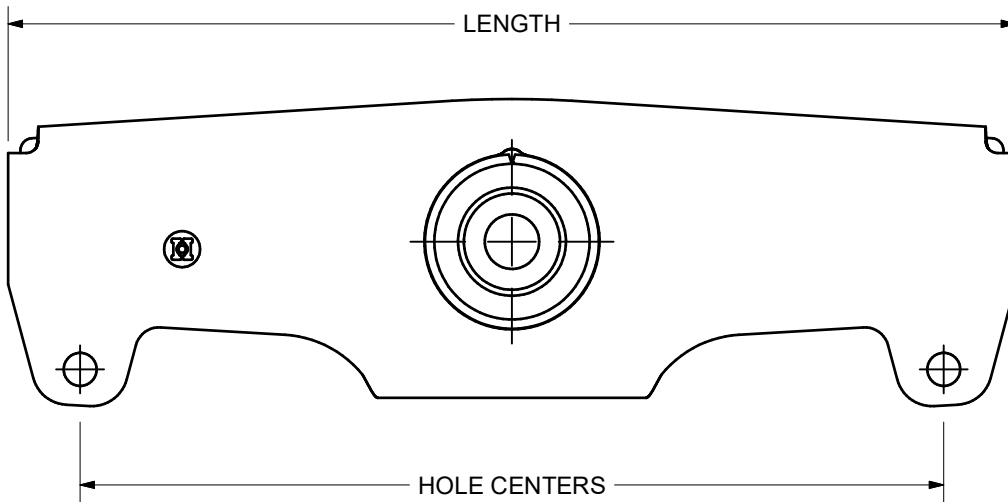

LENGTH	HOLE CENTERS	MODEL NO. (BUSHING TYPE)	PART NO.	COMMENTS
21.00	18.00	9700 (ONE BOLT)	24820-01	53.5/54.5" AXLE CENTERS NEW STYLE, FABRICATED
21.00	18.00	7700 (TWO BOLT)	24821-01	53.5/54.5" AXLE CENTERS NEW STYLE, FABRICATED

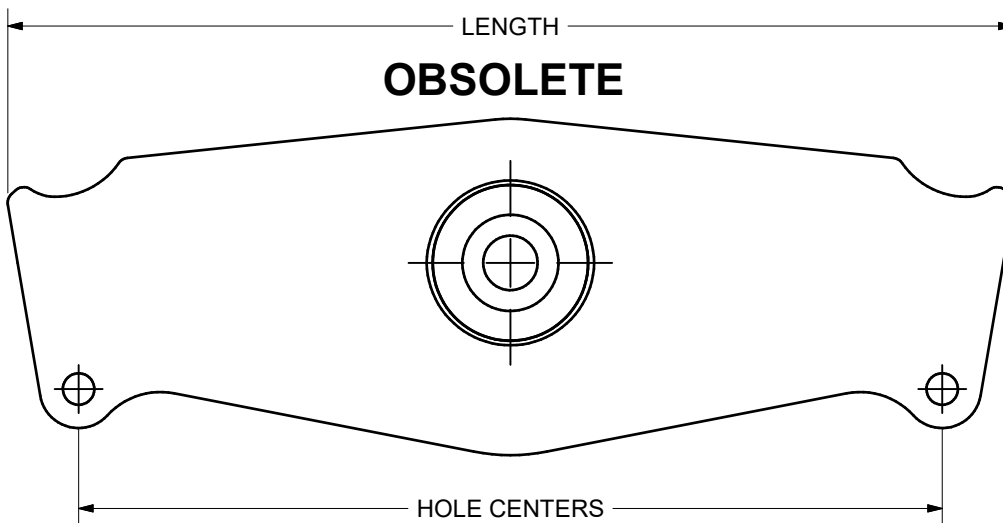

PART NUMBERS ARE GIVEN FOR REFERENCE ONLY USE THE 24820-01 AND 24821-01 FABRICATED VERSIONS

LENGTH	HOLE CENTERS	MODEL NO. (BUSHING TYPE)	PART NO.	COMMENTS
21.00	18.00	9700 (ONE BOLT)	16160-01 STEEL 24369-01 IRON	53.5/54.5" AXLE CENTERS NEW STYLE, FABRICATED, CAST
21.00	18.00	7700 (TWO BOLT)	12808-01 STEEL 24368-01 IRON	53.5/54.5" AXLE CENTERS NEW STYLE, FABRICATED, CAST

ROCKER IDENTIFICATION	ER: 2005122	REV: G	SHEET: 3 OF 7
	PROJ#: 20050500	REV DATE: 12/11/19	
		REV ER: 2019254	DRAWING NO.: 23663

HUTCHENS INDUSTRIES INC.

ROCKER IDENTIFICATION

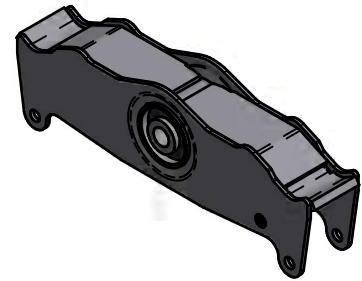
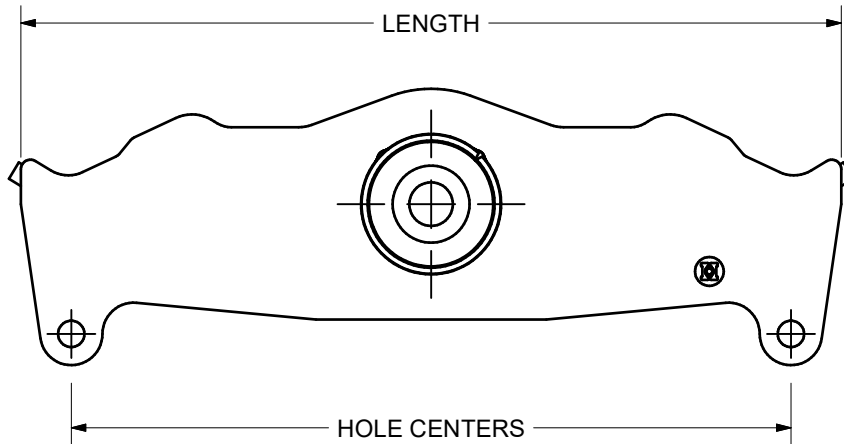

LENGTH	HOLE CENTERS	MODEL NO. (BUSHING TYPE)	PART NO.	COMMENTS
21.38	18.75	9700 (ONE BOLT)	24714-01	53.5/54.5" AXLE CENTERS OLD STYLE, FABRICATED
21.38	18.75	7700 (TWO BOLT)	24713-01	53.5/54.5" AXLE CENTERS OLD STYLE, FABRICATED

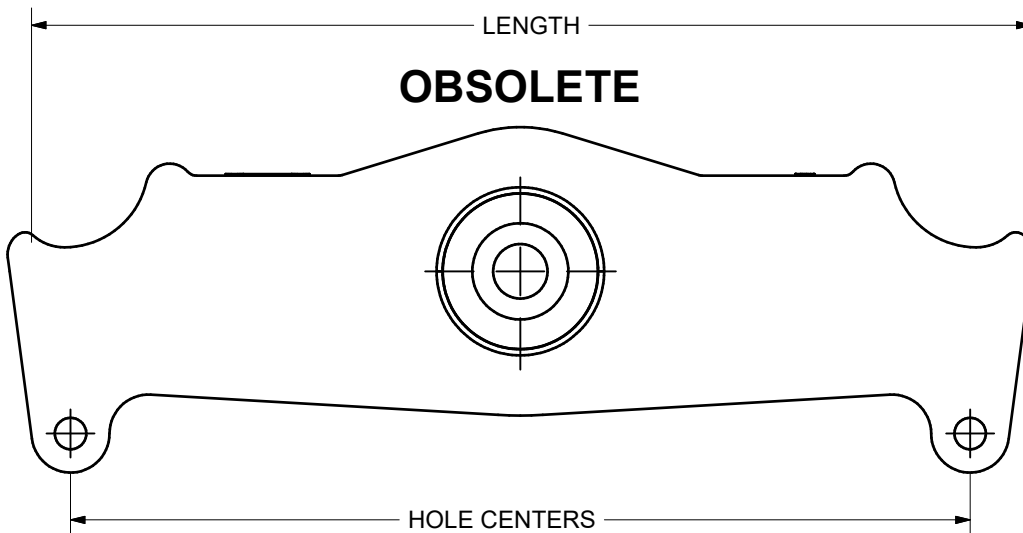

PART NUMBERS ARE GIVEN FOR REFERENCE ONLY USE THE 24714-01 AND 24713-01 FABRICATED VERSIONS

LENGTH	HOLE CENTERS	MODEL NO. (BUSHING TYPE)	PART NO.	COMMENTS
21.38	18.75	9700 (ONE BOLT)	16161-01 STEEL 24373-01 IRON	53.5/54.5" AXLE CENTERS OLD STYLE FABRICATED, CAST
21.38	18.75	7700 (TWO BOLT)	10385-05 STEEL 24372-01 IRON	53.5/54.5" AXLE CENTERS OLD STYLE FABRICATED, CAST

ROCKER IDENTIFICATION	ER: 2005122	REV: G	SHEET: 4 OF 7
	PROJ#: 20050500	REV DATE: 12/11/19	
		REV ER: 2019254	DRAWING NO.: 23663

HUTCHENS INDUSTRIES INC.

ROCKER IDENTIFICATION

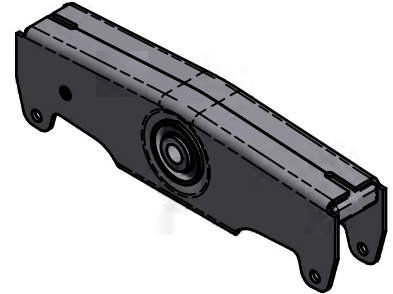
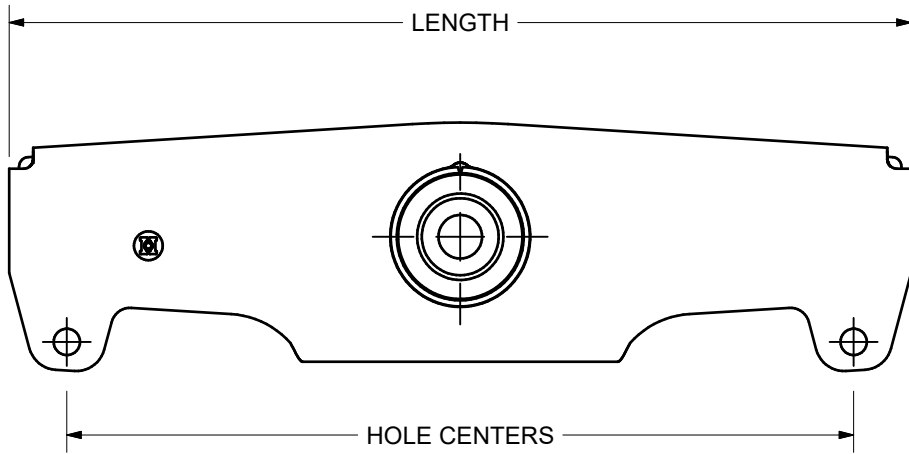

LENGTH	HOLE CENTERS	MODEL NO. (BUSHING TYPE)	PART NO.	COMMENTS
23.50	20.50	9700 (ONE BOLT)	21833-01	57.5" AXLE CENTERS FABRICATED
23.50	20.50	7700 (TWO BOLT)	21840-01	57.5" AXLE CENTERS FABRICATED

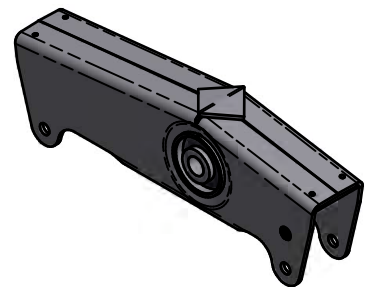
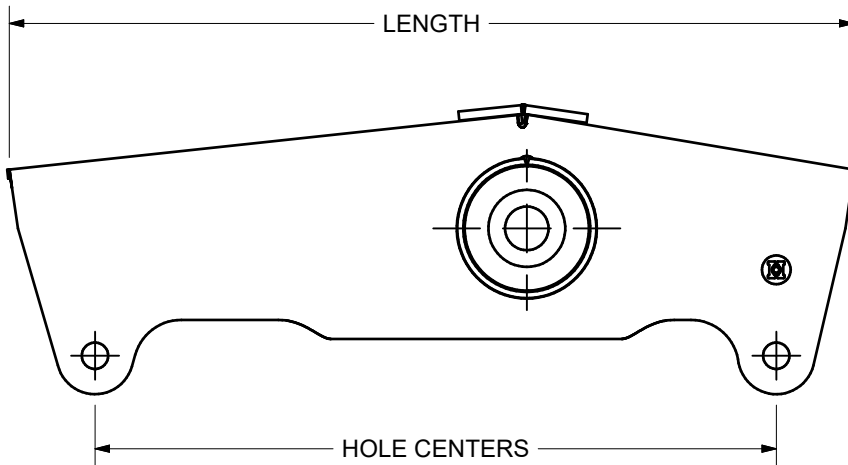

LENGTH	HOLE CENTERS	MODEL NO. (BUSHING TYPE)	PART NO.	COMMENTS
22.06	17.75	9700 (ONE BOLT)	17893-01	SINGLE-DUAL-SINGLE FABRICATED
22.06	17.75	7700 (TWO BOLT)	N/A	SINGLE-DUAL-SINGLE FABRICATED

ROCKER IDENTIFICATION	ER: 2005122	REV: G	SHEET: 5 OF 7
		REV DATE: 12/11/19	
	PROJ#: 20050500	REV ER: 2019254	DRAWING NO.: 23663

HUTCHENS INDUSTRIES INC.

ROCKER IDENTIFICATION

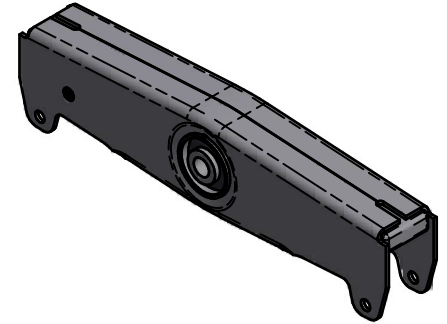
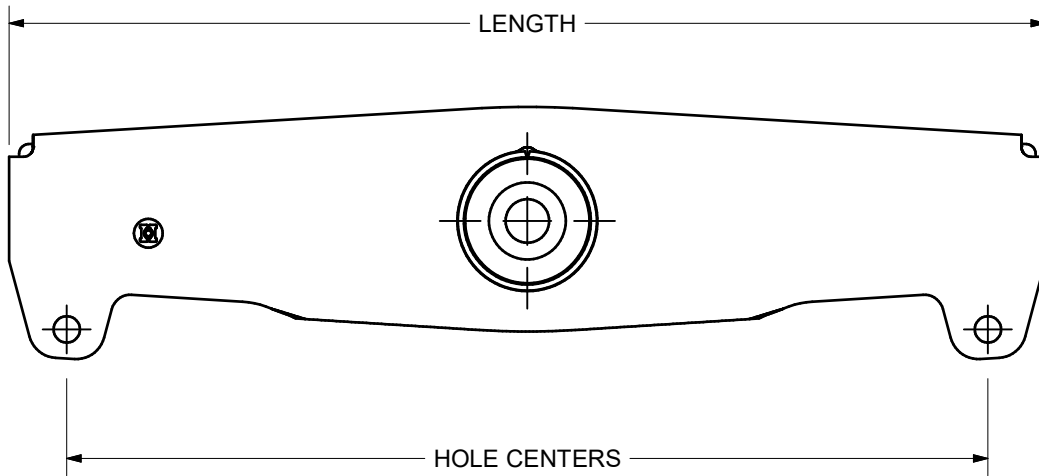

LENGTH	HOLE CENTERS	MODEL NO. (BUSHING TYPE)	PART NO.	COMMENTS
27.00	24.00	9700 (ONE BOLT)	21834-01	60/61" AXLE CENTERS FABRICATED
		7700 (TWO BOLT)	21841-01	
33.00	30.00	9700 (ONE BOLT)	16168-03	67" AXLE CENTERS FABRICATED
		7700 (TWO BOLT)	9239-03	
39.00	36.00	9700 (TWO BOLT)	21835-01	72/73" AXLE CENTERS FABRICATED
		7700 (TWO BOLT)	21842-01	
47.00	44.00	9700 (ONE BOLT)	16168-07	81" AXLE CENTERS FABRICATED
		7700 (TWO BOLT)	9239-07	
63.00	60.00	9700 (ONE BOLT)	16168-09	97" AXLE CENTERS FABRICATED
		7700 (TWO BOLT)	9239-09	
75.00	72.00	9700 (ONE BOLT)	16168-10	109" AXLE CENTERS FABRICATED
		7700 (TWO BOLT)	9239-10	
87.00	84.00	9700 (ONE BOLT)	16168-13	121" AXLE CENTERS FABRICATED
		7700 (TWO BOLT)	9239-13	
30.00	27.00	9700 (ONE BOLT)	16168-15	64" AXLE CENTERS FABRICATED
		7700 (ONE BOLT)	9239-15	
31.00	28.00	9700 (ONE BOLT)	16168-18	65" AXLE CENTERS FABRICATED
		7700 (TWO BOLT)	9239-18	

ROCKER IDENTIFICATION	ER: 2005122	REV: G	SHEET: 6 OF 7
		REV DATE: 12/11/19	
	PROJ#: 20050500	REV ER: 2019254	DRAWING NO.: 23663

HUTCHENS INDUSTRIES INC.

ROCKER IDENTIFICATION

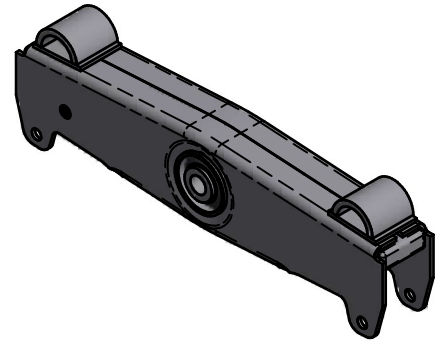
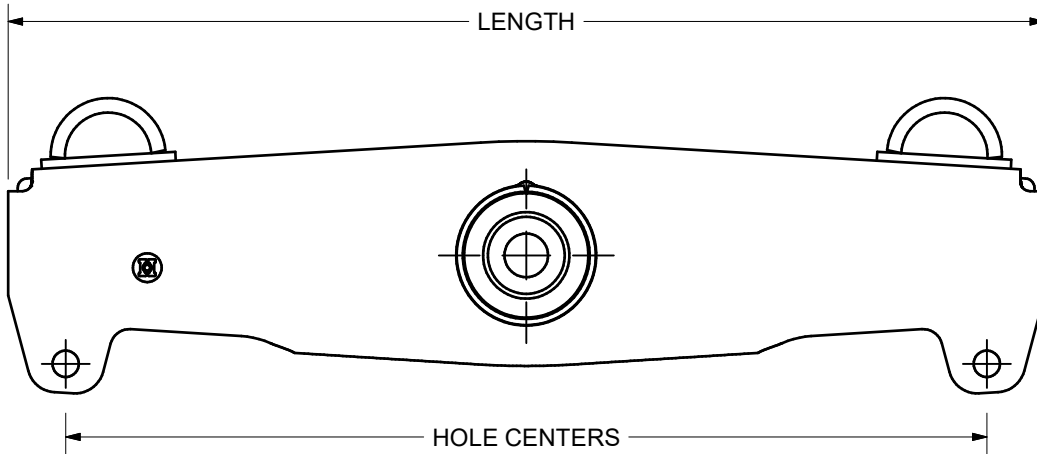

LENGTH	HOLE CENTERS	MODEL NO. (BUSHING TYPE)	PART NO.	COMMENTS
27.00	24.00	9700 (ONE BOLT)	24554-01	60/61" AXLE CENTERS FABRICATED
		7700 (TWO BOLT)	21847-01	60/61" AXLE CENTERS FABRICATED
39.00	36.00	9700 (ONE BOLT)	24677-01	72/73" AXLE CENTERS FABRICATED
		7700 (TWO BOLT)	24676-01	72/73" AXLE CENTERS FABRICATED
47.00	44.00	7700 (TWO BOLT)	12698-05	81" AXLE CENTERS FABRICATED

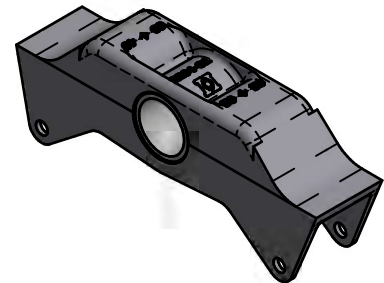
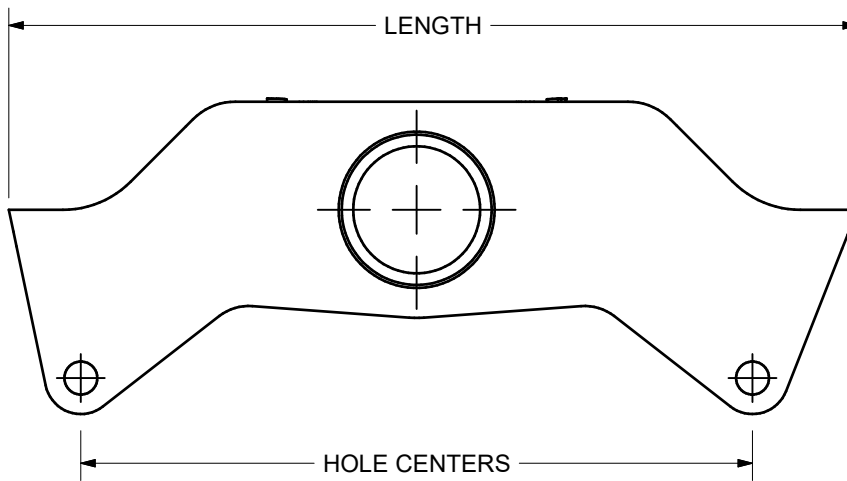

LENGTH	HOLE CENTERS	MODEL NO. (BUSHING TYPE)	PART NO.	COMMENTS
17.69	14.00	9700 (ONE BOLT)	18747-01	H2300 TRUCK SUSPENSION, CAST
17.69	14.00	7700 (TWO BOLT)	2224-02	H2300 TRUCK SUSPENSION, CAST

ROCKER IDENTIFICATION	ER: 2005122	REV: G	SHEET: 7 OF 7
		REV DATE: 12/11/19	
	PROJ#: 20050500	REV ER: 2019254	DRAWING NO.: 23663